

# Operation and Safety Instructions

## SERVEWELL® SL HOT FOOD TABLES



Model	Description
38203	3-Well 120V/1440W
38204	4-Well 120V/1920W
38205	5-Well 120V/2400W
38213	3-Well 120V/2100W
38214	4-Well 120V/2800W
38215	5-Well 120V/3500W
38217	3-Well 208-240V/1800-2400W
38218	4-Well 208-240V/2400-3200W
38219	5-Well 208-240V/3000-4000W

Thank you for purchasing this Hot Food Table. Before operating the unit, read and familiarize yourself with the following Operating and Safety Instructions. SAVE THESE INSTRUCTIONS FOR FUTURE REFERENCE.

## FUNCTION AND PURPOSE

This unit is intended to hold containers of hot food at proper serving temperature. This unit is not designed or intended to cook raw food or reheat prepared food.



### WARNING



### FIRE HAZARD

Do not operate this equipment without posts, shelf and legs or casters properly installed. The heating compartment must be separated from the supporting surface of the unit.

## ASSEMBLY

### BEFORE YOU BEGIN

#### IMPORTANT:

Place cardboard or a drop cloth on floor to protect work surface of unit during assembly.

### ASSEMBLY INSTRUCTIONS

- Remove all components from the shipping container. Each Vollrath ServeWell® SL unit is packed with the following assembly parts:

Description	Part Number	Quantity
Legs	28702-2	4
Stationary Peg Legs	23425-1	4
Screws	26530-3	32
Bottom Shelf	N/A	1
Drain Faucet	23424-2	1 per well

- Place the base assembly on the floor with well openings down and bottom pan facing up.



- Assemble the drain shut-off faucets to the tailpiece below each well. Hand-tighten until snug. Do not use Teflon® tape or any tools when assembling. Using tools will crack the drain assembly and result in water leaks.



- Attach the legs.
  - Prior to attaching the front legs, attach the support brackets under the plate rest. Then put screws through the brackets and legs into the base.

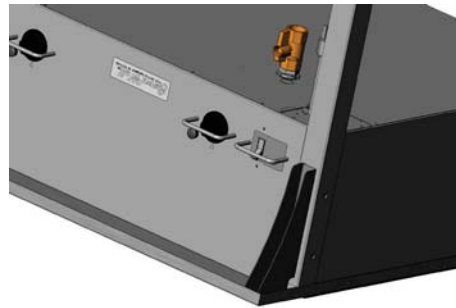

- Attach all the legs to the base using 16 screws (2 screws per top support bracket). The nuts for these screws are permanently attached inside the base.



- Attach the bottom shelf using 8 screws. Remember to face the top of shelf toward bottom of base.



- Attach each of the four stationary peg legs to the four triangular peg leg mounting plates using locknuts. The nuts are permanently attached inside the plates.

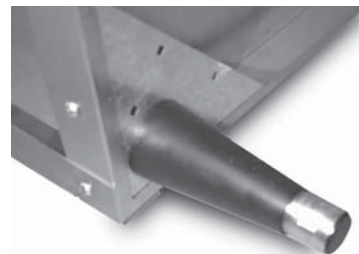

- Lift unit and set on its legs.



**OPERATION**



**WARNING**



**FIRE HAZARD**

Electric shock, fire or burn injuries can occur if this equipment is not used properly. To reduce risk of injury:

- Plug only into grounded electrical outlets matching the nameplate rated voltage.
- Unit should only be used in flat, level position.
- Unplug hot units and let cool before cleaning or moving.
- Do not spray controls or outside of unit with liquids or cleaning agents.
- Handle hot water carefully.
- Do not operate unattended.

**IMPORTANT:**

Do not operate this unit without water in wells.



**WARNING**



**FIRE HAZARD**

Do not operate this equipment without posts, shelf and legs or casters properly installed. The heating compartment must be separated from the supporting surface of the unit.

1. Fill each well with the following amount of water:

Model	Amount of Water
All models	4 Quarts

The water level mark inside the wells is at approximately 4 quarts. Do not overfill the wells. Do not operate the wells without water.



**WARNING**



**ELECTRICAL SHOCK HAZARD**

Keep water level at or below the required level. If level is too high, water may overflow when the food container is inserted. The overflow could enter the electrical compartment and cause a short circuit or electric shock.

2. Plug the power cord into an electrical outlet with nameplate rated voltage.

3. Preheat the water in the wells by covering the wells with empty food containers or covers, and then setting the heat control to the maximum heat setting. Preheat times:

Model	Preheat Time
All models	60 minutes

4. Place containers of hot food into the preheated food warmer wells. To prevent spills, do not overfill the food containers.
5. Set the heat control to maintain safe food holding temperature. Monitor food temperatures closely for food safety. (See food safety note.)

**FOOD SAFETY PRECAUTIONARY NOTE**

Monitor food temperatures closely for food safety. The United States Public Health Service recommends that hot food be held at a minimum of 140° F (60° C) to help prevent bacteria growth. Maintain water level at approximately 3/8" from the bottom of the well. Periodically (approximately every 2 hours) remove container of food and check the water level. Add hot water if needed.



**WARNING**



**BURN HAZARD**

Hot water and steam in the well can burn skin. Use protective gloves, mitts or pot holders when removing food containers or covers. Hot food can also cause burns. Handle hot food carefully.

**CLEANING**

To maintain appearance and increase the service life, the food warmer should be cleaned at least daily.



**WARNING**



**ELECTRICAL SHOCK HAZARD**

Do not spray water or cleaning product. Liquid could enter the electrical compartment and cause a short circuit or electric shock.

1. Before cleaning or moving, unplug the unit and let it cool completely.
2. Carefully drain water from the wells.
3. Wipe the entire interior of each water pan and well with a clean, damp cloth.
4. To avoid damaging the finish, do not use abrasive materials, scratching cleaners or scouring pads to clean water deposits from the wells.
5. If soap or chemical cleaners are used, be sure they are completely rinsed away with clear water, immediately after cleansing. Chemical residue could corrode the surface of the unit.

**REPAIR**

There are no user serviceable parts within this appliance. To avoid serious injury or damage, never attempt to repair the food warmer or replace a damaged power cord yourself.

Contact a competent professional repair service.



**WARNING**



**ELECTRICAL SHOCK HAZARD**

Do not use this equipment if any well has been removed. Contact with any metal part could cause an electrical shock resulting in severe injury or death.

**TROUBLESHOOTING**

If	It might be caused by	Course of action
One well does not get as hot as all the others.	Thermostats could be out of calibration.	To test, when the unit is cold, turn the thermostat from the off position slowly to full on. You should hear a “click” at about the second or third position. If the click is heard much later, the thermostats are out of calibration and must be replaced. Knocking the thermostats can cause them to be thrown out of calibration.
Elements burn out after a short time.	Operators often plug 120V 5-30 and 5-50 plugs into 208V or 240V receptacles.	Check the power supply.
	Elements must always be covered with water. If the unit is used without water, the elements will burn out prematurely.	Check water levels often to ensure elements are always covered with water.
Drains leak.	Drain valve is obstructed.	Check for obstructions preventing the valve from closing properly.
	Plastic drain adapter is cracked where the brass reducer or valve is screwed into drain adapter.	The drain parts should be hand tightened only. Teflon tape should not be used when installing drain valves. Over-tightening the drain parts will crack the plastic
Unit heats when thermostat dial is in off position.	Thermostat is wired wrong.	Wires should be on terminals 1 and 2.
	Thermostat is damaged and must be replaced.	Contact an authorized Service Center.
Unit does not get hot enough.	Too much water.	See page 3 for proper water level and pre-heating time.
	Improper voltage.	Check to see the unit has the proper voltage. A unit requiring 120V supply will not perform properly if the voltage supplied is low.



## WIRING DIAGRAM

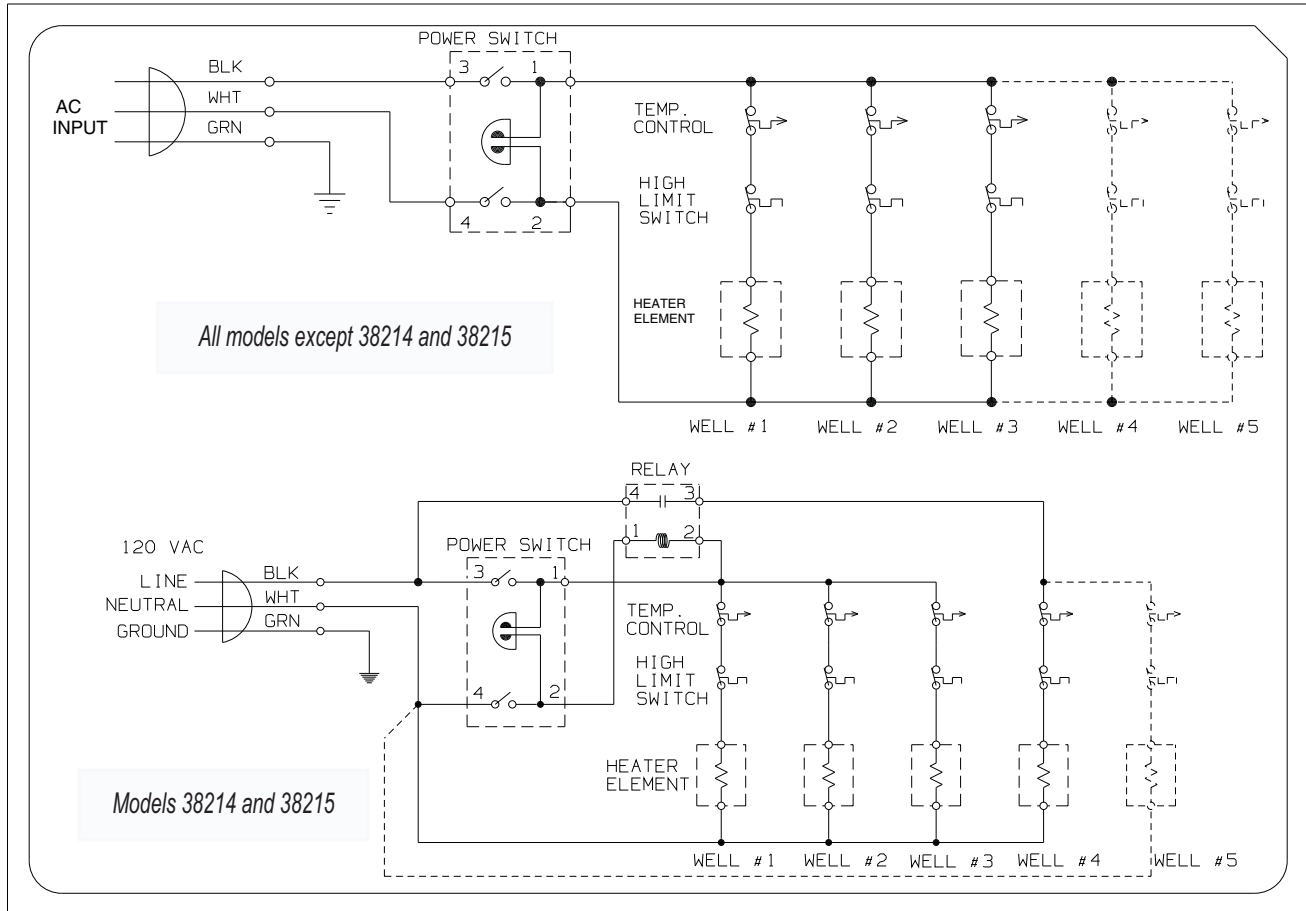

## SERVEWELL® SL OPERATION

All units come standard with a properly rated cord and plug. Power is controlled first by a double pole lighted switch. The switch, when closed, allows power to the thermostats. The thermostats are capillary bulb thermostats that will react to temperature changes as transmitted to the bulb through the element casting. When the thermostats close, power is then sent to the high limit switch. The high limit switch is normally closed. It will open if the temperature exceeds  $175^{\circ}\text{C} \pm 9^{\circ}$  for safety. Power passing through the high limit switch will then energize the element. The neutral wire (or secondary load wire in 208V or 240V systems) from the switch is connected directly to the element.

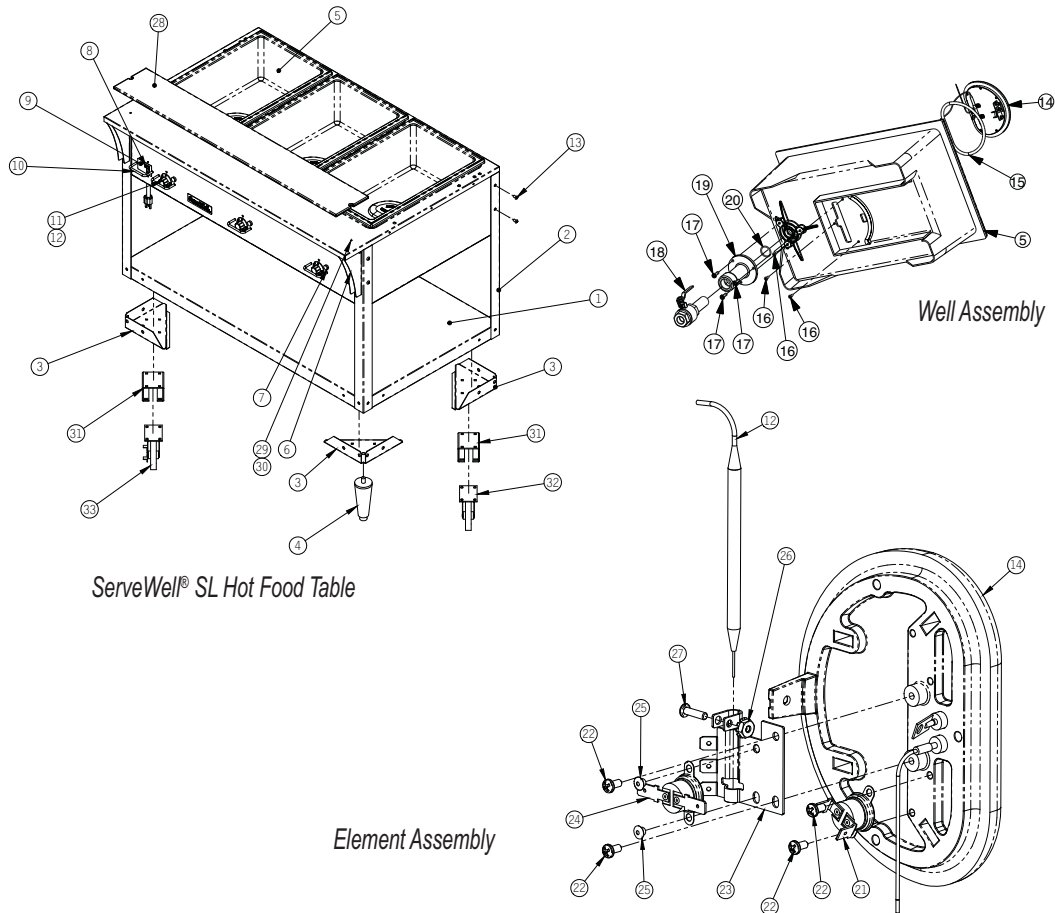
**EXPLODED VIEW**

ServeWell® SL Hot Food Table

Well Assembly

Element Assembly

3-Well unit shown. 4 and 5-Well units use the same parts, except where noted.

Item	Part No.	Description
1	28704-2	Shelf, bottom for 3-well
	28729-2	Shelf bottom for 4-well
	28715-2	Shelf bottom for 5-well
2	28702-2	Upright leg
3	28707-2	Bracket, caster
4	23425-1	Leg, adjustable
5	17533-1	Well, plastic (Mfg. After 7/1/00)
6	2871101-2	Bracket, top support
7	1755901-1	Low water light
8	23540-1	Switch, toggle. DPST, 30A
9	21607-1	Label, switch
10	17749-1	Guard, knob
11	23423-1	Knob, thermostat
12	17124-1	Thermostat
13	26530-3	Screw, #1/4-20 x .500
14	44200-1	Element for 38203, 38204, 38205
	44204-1	Element for 38213, 38214, 38215
	44277-1	Element for 38217, 38218, 38219
15	17868-1	Gasket, element
16	17014-3	Screw, #10-32 x .50 Lg.

Item	Part No.	Description
17	17651-3	Screw, #14 x .750 thread cutting
18	23424-2	Valve and nipple assembly
19	17362-1	Drain Adapter
20	17365-3	O-Ring adapter, drain
21	25438-1	Thermostat, regulating
22	17496-3	Screw, #6-32 x .250 Lg.
23	17928-1	Bracket, thermostat
24	17950-1	Switch, high limit
25	23686-3	Rivet
26	17019-3	#6-32 keps nut
27	17020-3	Screw, #6-32 x .500 Lg.
28	2342901	Cutting board for 3-well (optional)
	2343101	Cutting board for 4-well (optional)
	2343201	Cutting board for 5-well (optional)
29	17757-3	Screw, #10-24 x .25 Lg. (optional)
30	17236-3	Nut, acorn #10-24 (optional)
31	28789-2	Spacer with optional caster (optional)
32	29838-1	Caster - 4" swivel (optional)
33	26185-1	Caster - 4" swivel w/brake (optional)



## WARRANTY STATEMENT FOR THE VOLLRATH CO. L.L.C.

The Vollrath Company L.L.C. warrants the products it manufactures and distributes against defects in materials and workmanship for a period of one year, except as specifically provided below. The warranty runs 12 months from the date of original installation. (End user receipt)

- Refrigeration compressors – The warranty period is 5 years.
- Replacement parts – The warranty period is 90 days.
- Fry pans and coated cookware – The warranty period is 90 days.
- EverTite™ Riveting System – The warranty covers loose rivets only, forever.
- Cayenne® Heat Strips – The warranty period is 1 year plus an additional 1 year period on heating element parts only.
- Intrigue™ Ultra and Professional Induction Ranges – The warranty period is 2 years.
- ServeWell® Induction Workstations – The warranty period is one year on the workstation table and 2 years on induction hobs.
- Slicers – The warranty period is 10 years on gears and 5 years on belts.
- Mixers – The warranty period is 2 years.
- Extended warranties are available at the time of sale.

All products in the Jacob's Pride® collection, including the following, have a lifetime warranty:

- NSF Certified One-Piece Dishes
- NSF Certified Spoodle® Utensils
- NSF Certified Heavy-Duty Spoons with Ergonomic Handle
- NSF Certified Heavy-Duty Basting Spoons
- Heavy duty Turners with Ergonomic handle
- One-Piece Tongs\*
- Heavy-Duty One-Piece Ladles\*
- Nylon Handle Whips
- One-Piece Skimmers
- Tribute®, Intrigue®, and Classic Select® Cookware\*

\*Jacob's Pride® warranty does not cover Kool-Touch®, non stick coatings and silicone handles.

Items sold having no warranty:

- Meat Grinder Knives
- Light Bulbs in Convection Ovens and Hot Food Merchandiser
- Oven Door Seal
- Oven Door Glass
- Hot Food Merchandisers / Display Case Glass
- Calibration and set up of gas equipment

THIS WARRANTY IS IN LIEU OF ANY OTHER WARRANTIES, EXPRESS OR IMPLIED, INCLUDING ANY IMPLIED WARRANTY OF MERCHANTABILITY OR FITNESS FOR A PARTICULAR PURPOSE

### WARRANTY PROCEDURE

On all warranty calls, the following process and information is required:

- All warranty claims will start with a call to Vollrath Technical Service support line. (800-628-0832).
- A technical support professional will work to diagnose the issues, and provide the details for the service solution.
- Name and phone number of person calling
- Business name, street address, city, state and zip
- Model and serial number
- Date of purchase and proof of purchase (Receipt)
- Name of dealer where unit was purchased

**IMPORTANT**  
TO MAKE A CLAIM FOR ANY  
REMEDY UNDER THIS  
WARRANTY, YOU MUST  
REGISTER YOUR WARRANTY.

NOTE: Vollrath will not accept products sent without the proper procedure being followed.

### REGISTER TODAY

ONLINE: Register your warranty on-line now at [www.Vollrathco.com](http://www.Vollrathco.com)

FAX: If you do not have access to the web, kindly register by completing the warranty registration form and faxing it to The Vollrath Co. LLC office in the country of purchase.

WARRANTY REGISTRATION			
BUSINESS NAME			
KEY CONTACT NAME		EMAIL	
STREET ADDRESS			
CITY		STATE	ZIP CODE
COUNTRY		PHONE	FAX
MODEL		ITEM NUMBER	
SERIAL NUMBER <span style="display: inline-block; width: 100px; border-bottom: 1px solid black;"></span> - <span style="display: inline-block; width: 100px; border-bottom: 1px solid black;"></span> - <span style="display: inline-block; width: 100px; border-bottom: 1px solid black;"></span>			
OPERATION TYPE			
<input type="checkbox"/> Limited Service Restaurant	<input type="checkbox"/> Full Service Restaurant	<input type="checkbox"/> Bars and Taverns	<input type="checkbox"/> Supermarket
<input type="checkbox"/> Convenience Store	<input type="checkbox"/> Recreation	<input type="checkbox"/> Hotel/Lodging	<input type="checkbox"/> Airlines
<input type="checkbox"/> Business/Industry	<input type="checkbox"/> Primary/Secondary School	<input type="checkbox"/> Colleges/University	<input type="checkbox"/> Hospitals
<input type="checkbox"/> Long-Term Care	<input type="checkbox"/> Senior Living	<input type="checkbox"/> Military	<input type="checkbox"/> Corrections
REASON FOR SELECTING OUR PRODUCT			
<input type="checkbox"/> Appearance	<input type="checkbox"/> Full Service Restaurant	<input type="checkbox"/> Availability	<input type="checkbox"/> Sellers Recommendation
<input type="checkbox"/> Ease of Operation	<input type="checkbox"/> Versatility of Use	<input type="checkbox"/> Price	<input type="checkbox"/> Brand
WOULD YOU LIKE TO RECEIVE OUR FULL-LINE CATALOG AND REMAIN ON OUR MAILING LIST?			<input type="checkbox"/> Yes <input type="checkbox"/> No

ENGLISH



[www.vollrathco.com](http://www.vollrathco.com)

The Vollrath Company, L.L.C.  
1236 North 18th Street  
Sheboygan, WI 53081-3201  
U.S.A.  
Main Tel: 800.628.0830  
Service Tel: 800.628.0832  
Service Fax: 800.309.2231

Vollrath of Canada, Co  
Tel: 800.695.8560  
Fax: 800.752.5620