

Project \_\_\_\_\_

Item Number \_\_\_\_\_

Quantity \_\_\_\_\_

4610



## 4610 Economy Slicer

### Model:

➤ 4610: 1/4hp Manual Slicer



CERTIFIED BY NSF INTERNATIONAL TO MEET AND EXCEED THE NSF/ANSI 2012 STANDARDS

10" Precision slicing German hollow ground blade  
 Unique smooth curve transitions to redirect liquids away from controls and operator  
 Easily detachable carriage for easy cleaning

Economy Series Slicer

### Features:

- Light duty, intermediate volume slicer
- Maximum duty 2 hours a day
- Unique drip tray fence redirects liquids away from controls and operator towards distinctive concave base casting for easy cleaning
- Ergonomic comfort design operation
- Powerful 1/4 hp motor standard
- Adjustable slice thickness from 0 to 1/2"
- Easily removable sharpener for cleaning
- Quick and simple disassembly of carriage and feed grip for easy and thorough cleaning
- Sanitary polished and anodized aluminum construction
- Permanently mounted protective edge guard for operator safety

Univex Corporation

### Optional Accessories:

- Stainless steel blade
- Heavy duty clear plastic cover
- Sturdy stainless steel stand

### Warranty:

- One year, carry-in parts and labor



WE RAISE THE BAR. WE SET THE STANDARD.

# Economy Series Slicer

# 4610

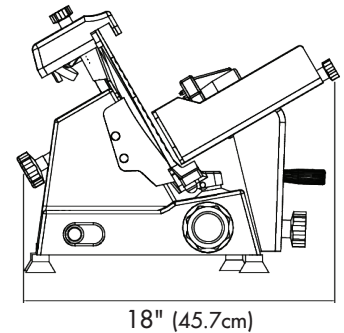
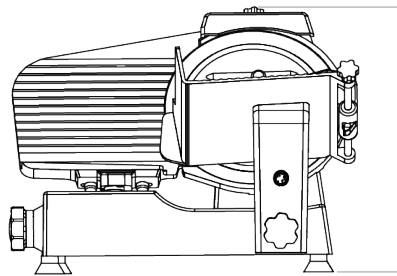
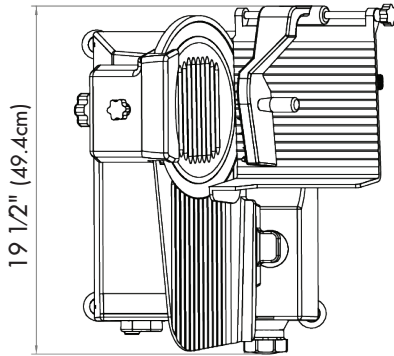

Controls: Manual slice thickness knob, push button on/off, attached blade sharpener

Drive Assembly: Belt driven

Blade diameter: 10" (25.4cm) razor sharp blade

Blade RPM: 420 RPM

Maximum Slice thickness: .5" (1.27cm)

Maximum product size: Rectangular: 8" x 5" (20.3cm x 13.3cm)

Square: 5" x 5" (13.3cm x 13.3cm)

Round: 7" (20.3cm)

Construction: Anodized, cast aluminum body for durability and stunning looks

Nema #: 5-15-P

### Electrical Information (60Hz)

	Voltage	Phase	Amps	RPM	hp(kW)
Standard Voltage	115	1	1.9	1680	1/4 (.19)
Optional Voltage	208-240	1	1.0	1680	1/4 (.19)

### Carriage Stroke

9.25" (23.5cm)

### Shipping Information

Net Weight	Shipping Weight	Overall Shipping Dimensions
46.1lbs. (20.9Kg)	55lbs. (25Kg)	21" (53.3cm) H x 27" (68.6cm) W x 23" (58.4cm) D



**Univex Corporation**  
[www.Univexcorp.com](http://www.Univexcorp.com)

3 Old Rockingham Rd  
Salem, NH 03079  
United States of America

TEL: (800)258-6358  
INTL TEL: (603)893-6191  
FAX: (800)356-5614  
INTL FAX: (603)893-1249