



# VEGETABLE PREPARATION MACHINE CA-301

Commercial vegetable preparation machine with an hourly output of up to 450 Kg.



## SALES DESCRIPTION

1 speed motor block and a universal attachment.

## FEATURES AND BENEFITS

- ✓ Stainless steel construction and highest quality material, all suitable for contact with food.
- ✓ New production technology that gives a uniform, high-quality cutting result.
- ✓ Ergonomic design: product is sliced/cut/shredded in one single movement.
- ✓ The large range of high quality discs and grids allows the operator to obtain over 70 different styles of product. Discs are not included.
- ✓ Lateral product ejection, reducing the amount of counter space required, whilst also minimising product splashing.
- ✓ This directs the product avoiding splashing.
- ✓ Electronic, user-friendly control board.
- ✓ Easily removable lever and lid for cleaning purposes.
- ✓ NSF-International certified appliance (complying with Hygiene, Cleaning and Food Material regulations).

## INCLUDES

- ✓ 1 speed motor block.
- ✓ Regular hopper.

## ACCESSORIES

- FC Slicing Disc
- FCC Curved Slicing Discs
- FCO Rippled Slicing Discs
- FFC Chipping Grids
- FMC Dicing Grids
- FCE Julienne Discs
- FR/SH Shredding & Grating Discs
- Long vegetable attachment
- Disc and Grid Holder Device
- Grid Cleaning Kit



**sammic** | [www.sammic.com](http://www.sammic.com)  
Food Service Equipment Manufacturer

Polígono Basarte, 1. phone +34 943 15 72 36  
20720 Azkoitia, Spain sales@sammic.com



Project	Date
Item	Qty
Approved	

DYNAMIC PREPARATION  
COMMERCIAL VEGETABLE PREPARATION MACHINES

product sheet  
updated 01/02/2019



# VEGETABLE PREPARATION MACHINE CA-301

Commercial vegetable preparation machine with an hourly output of up to 450 Kg.



## SPECIFICATIONS

Hourly production: 150 Kg - 450 Kg

Inlet opening: 136 cm<sup>2</sup>

Disc diameter: 205 mm

Motor speed: 365 rpm

### Loading

Single Phase: 550 W

Three phase: 370 W

**Noise level (1m.):** 70 dB(A)

**Background noise:** 32 dB(A)

### External dimensions (WxDxH)

Width: 389 mm

Depth: 405 mm

Height: 544 mm

Net weight: 21 Kg

### Crated dimensions

435 x 430 x 600 mm

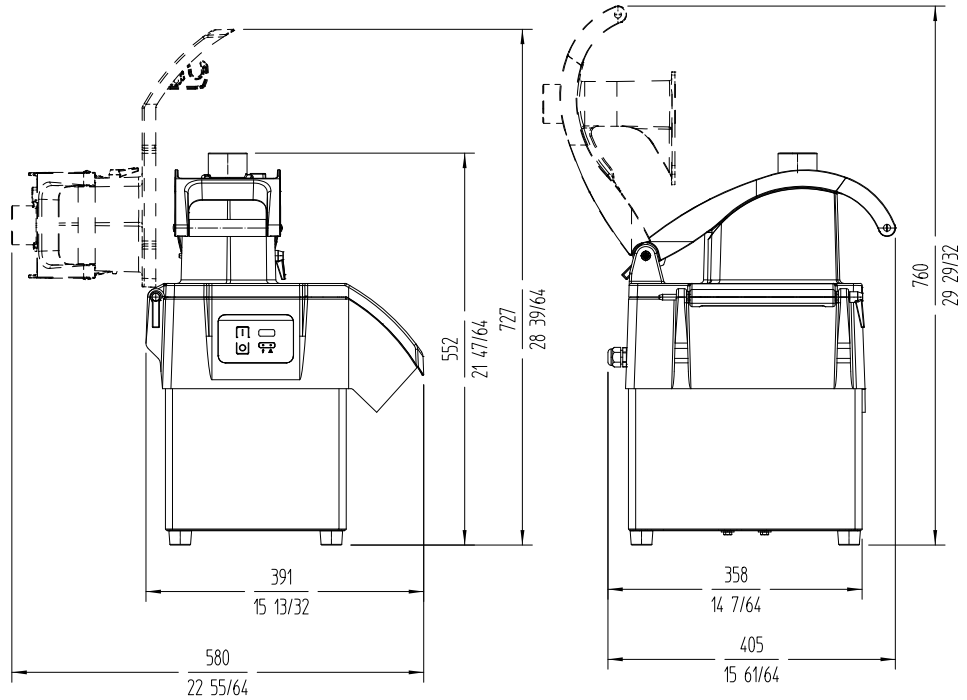

DYNAMIC PREPARATION  
COMMERCIAL VEGETABLE PREPARATION MACHINES

## AVAILABLE MODELS

1050301 Vegetable preparation machine CA-301 230-400/50/3N

1050021 Vegetable preparation machine CA-301 230/50/1

\* Ask for special versions availability

**sammic** | www.sammic.com  
Food Service Equipment Manufacturer

Polígono Basarte, 1. phone +34 943 15 72 36  
20720 Azkoitia, Spain sales@sammic.com



Project	Date
Item	Qty
Approved	

product sheet  
updated 01/02/2019