

## Combination Continuous Feed Vegetable Prep and Vertical Cutter Mixer

Prepare Sauces and  
Pate' in Bowl Unit



R301 Series D  
Model has Gray  
Bowl



R301U Series D  
Model has Stainless  
Steel Bowl

Prepare 2000 restaurant servings  
in 3 hours. Healthcare facilities  
can prepare puree diets daily for 12  
residents.

Vegetable prep attachment  
designed for quality continuous  
feed slicing, shredding, grating,  
french fry, and julienne cuts.  
Accommodates 21 different  
processing discs. Bowl attachment  
designed for vertical cutting and  
mixing functions: Mix, chop, puree,  
and blend.



- 1.5 H.P. single phase motor with magnetic safety switch. Push button "On-Off" and "Pulse" switches.
- New motor base and vegetable prep attachment designed to be more user friendly, better sanitation and made from new material that is more resistant to chemical agents for a longer life span.
- New cutter bowl and lid design with:
  - R301 Series D - Gray Bowl
  - R301U Series D - Stainless Steel Bowl
  - ergonomic handle for easier handling.
  - 10% increased liquid capacity due to higher hub.
  - new safety system improves the life span of lid and safety rod.
- New integrated ventilation system position for better sanitation.
- Great disc selection to accommodate most veg prep applications.
- Attachments easily removed for assured sanitation.
- Unit base uses 13 1/16" x 11 15/16" of counter space.
- Packed with two processing discs (R209, 5/64" grating disc & R211, 5/32" slicing disc) as standard.
- 1 year parts and labor warranty.

Robot Coupe U.S.A., Inc.  
P.O. Box 16625  
Jackson, MS 39236-6625  
1-800-824-1646 • (601) 898-8411  
FAX: (601) 898-9134  
www.robotcoupeusa.com • e-mail: info@robotcoupeusa.

# R301 & R301U

Commercial Food Processor

## Specifications

**R301 SERIES D STANDARD MODEL:** includes motor base unit with gray ABS plastic cutter bowl, stainless steel "S" blade, continuous feed attachment, one 1/8" (3mm) slicing disc and one 1/8" (3mm) medium grating disc and discharge plate.

**R301U SERIES D STANDARD MODEL:** includes motor base unit with stainless steel cutter bowl, stainless steel "S" blade, continuous feed attachment, one 1/8" (3mm) slicing disc and one 1/8" (3mm) medium grating disc and discharge plate.

**ELECTRICAL REQUIREMENTS:** 120V, 60Hz, 9 Amps, single phase. Contact your local electrician for local code requirements.

**SWITCHING:** Control panel with push-type on / off and pulse buttons.

**MOTOR:** 1.5 HP, 1725 RPM, direct-drive, fan-cooled.

**WEIGHT:** 40 lbs. net, 42 lbs. approximate shipping weight.

## Available Disc Selection

### Slicing Discs

- 27051 - 1/32" (1mm)
- 27555 - 5/64" (2mm)
- 27086 - 1/8" (3mm)
- 27566 - 5/32" (4mm)
- 27087 - 3/16" (5mm)
- 27786 - 1/4" (6mm)

### Ripple Cut Slicers

- 27621 - 5/64" (2mm)

### Graters

- 27588 - 1/16" (1.5mm)
- 27577 - 5/64" (2mm)
- 27511 - 1/8" (3mm)
- 27046 - 1/4" (6mm)
- 27632 - 11/32" (9mm)
- 27078 - Hard Cheese Grate

### Pulping

- 27079 - Fine pulping disc
- 27764 - Pulping disc

### Julienne

- 27599 - 5/64" (2x2mm)
- 27080 - 5/64" x 5/32" (2x4mm)
- 27081 - 5/64"x1/4" (2x6mm)
- 27047 - 5/32" (4x4mm)
- 27610 - 1/4" (6x6mm)
- 27048 - 5/16" (8x8mm)

**OPTIONAL EQUIPMENT:** 19 additional processing discs.

**STANDARDS:** ETL electrical & sanitation, cETL (Canada)

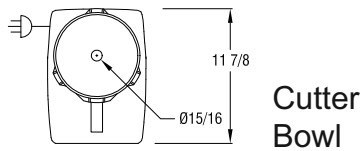

Cutter Bowl

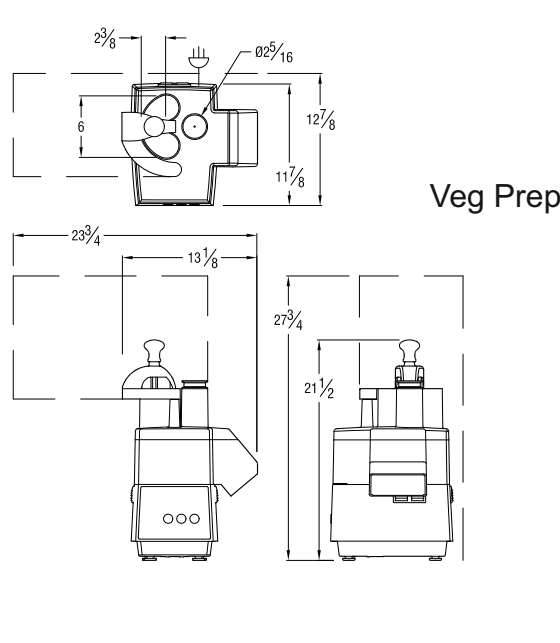
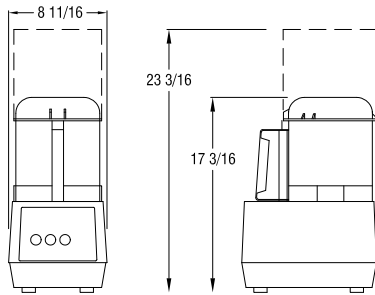

Veg Prep

Robot Coupe U.S.A., Inc.

P.O. Box 16625

Jackson, MS 39236-6625

1-800-824-1646

(601) 898-8411

FAX: (601) 898-9134

www.robotcoupeusa.com

e-mail: info@robotcoupeusa.com

## Distributed by: