

FINALLY, a Deck Oven Bake in a Conveyor!

EXCLUSIVE *Hearth Bake Belt* is designed for use on the **WOW!** Oven to create the perfect deck oven crust in a conveyor oven!



PATENTS PENDING

Principle

Middleby Marshall PS Series conveyor ovens bake both faster and at a lower temperature than other ovens. All PS640 WOW! ovens are designed to cook 30% faster than other conveyor ovens. The *Hearth Bake Belt* produces a “deck oven” bake. The pizza is placed directly on the tightly meshed belt and cooks with impingement and conduction heat. This surpasses the use of screens and gives the user a superior advantage over other conveyor ovens. Operationally, the conversion from a deck oven to this system is seamless.



Standard Features

- **Impingement PLUS!** low oven profile and dual air return
- **Patented EMS energy Management System** reduces gas consumption and increases cooking efficiency
- 40-1/2” (1029mm) long cooking chamber
- 33-1/2” (851mm) wide, 76-1/2” (1943mm) long conveyor belt
- High speed conveyor (Range of 2:00 - 30:00)

Speed

- Advanced technology air delivery system bakes up to 30% faster than standard conveyor ovens

Energy Management System

The PS640 WOW!™ oven features an Energy Management System (EMS) that automatically reduces gas consumption. Touch Screen Control can be programmed in one energy saving mode. Automatic “energy eye” saves gas when no pizzas are in the oven

Optional Features

- *Hearth Bake belt* for a deck oven crust
- Split belt - two 15” (381mm) belts with individually adjustable speed settings
- 6” Legs for double stack

Cleanability

PS640 Ovens are designed for easy cleaning. Removable parts include: crumb pans, end panels, air fingers, and a folding conveyor belt assembly.

Easily Serviced

Control compartment is designed for quick and easy access.

Warranty

All PS640 models have a one year parts and labor warranty. Oven start-up is included at no additional charge (USA Only). Factory demo available at additional charge

Ventilation

For installation under a ventilation hood only.

NOTE: Drawings show ovens equipped with casters.

PS640-1

TOP VIEW

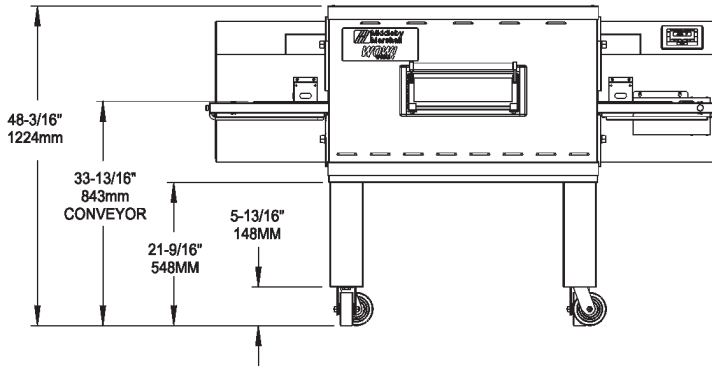
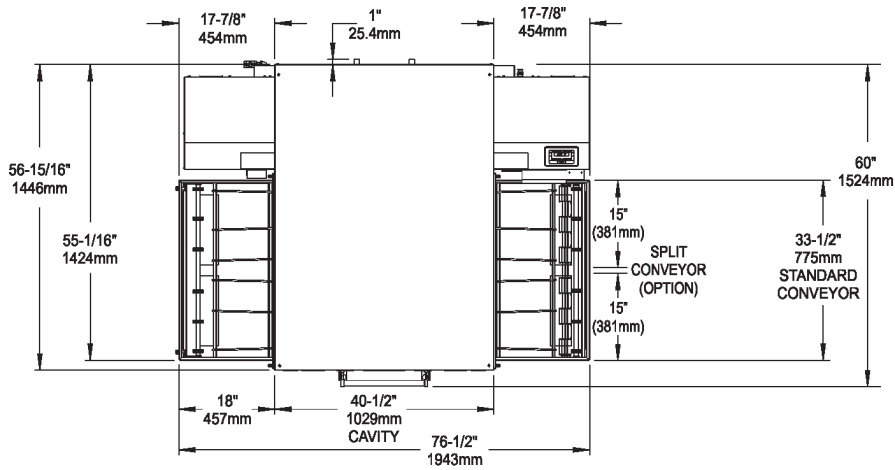

FRONT VIEW

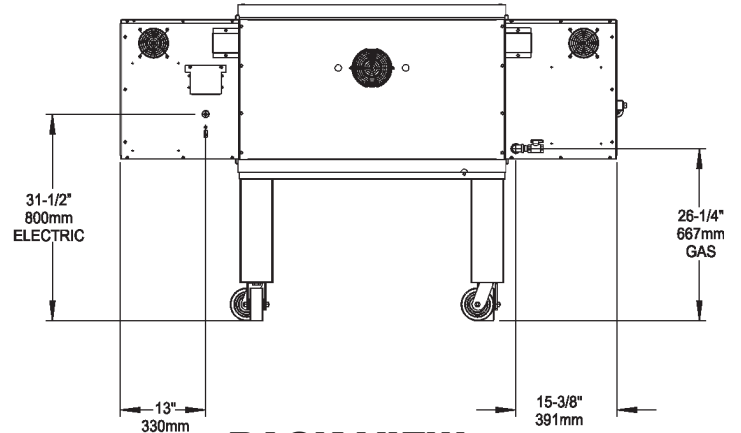

BACK VIEW

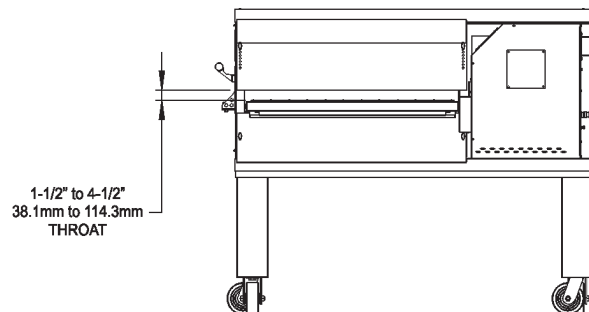

SIDE VIEW

NOTE: Drawings show ovens equipped with casters.

PS640-2

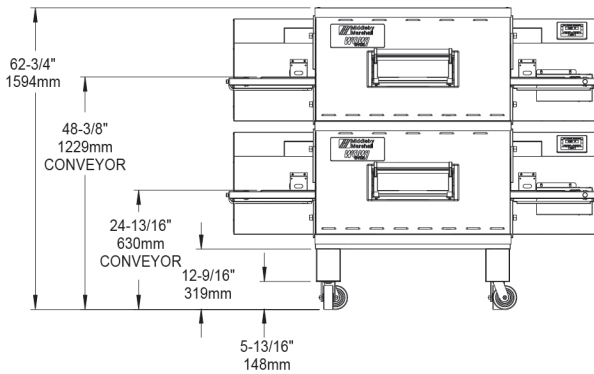

FRONT VIEW

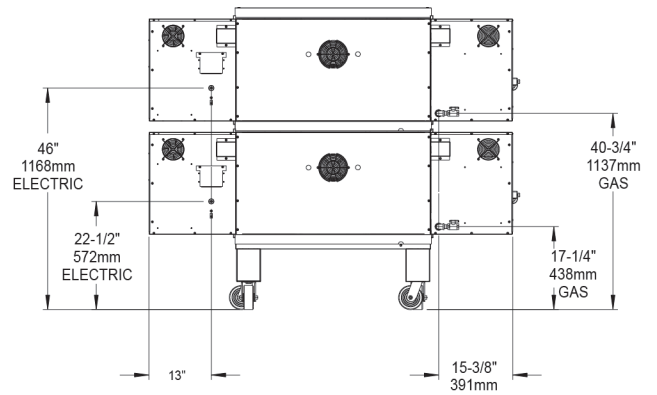

BACK VIEW

PS640-3

SHOWN WITH OPTIONAL OUTRIGGERS

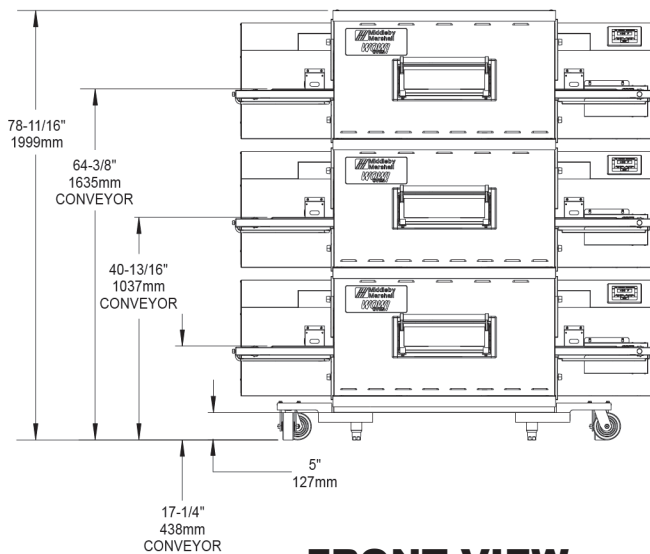

FRONT VIEW

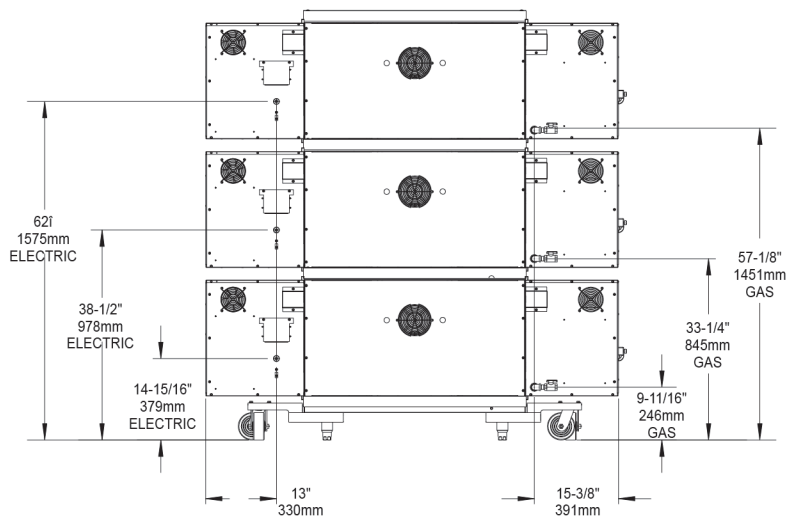

BACK VIEW

RECOMMENDED MINIMUM CLEARANCES

Rear of Oven to Wall	Control end of conveyor to wall	Non-control end of conveyor to wall
0"	0"	0"

GENERAL SPECIFICATIONS

	Heating Zone	Baking Area	Belt Length	Belt Width	Length	Height	Depth	Maximum Operating Temp	Bake Time Range	Ship Wt	Ship Cube
PS640-1	40-1/2" 1028mm	9sq.ft. 0.837m ²	76-1/2" 1943mm	1x32" (813mm) or 2x15" (381mm)	76-1/2" 1943mm	48-3/16" 1224mm	60" 1537mm	600°F 315°C	2:00 - 30:00	1100lbs. 499kg	132ft ³ 3.70m ³
PS640-2	81" 2056mm	18sq.ft. 1.674m ²	76-1/2" 1943mm	1x32" (813mm) or 2x15" (381mm)	76-1/2" 1943mm	62-3/4" 1594mm	60" 1537mm	600°F 315°C	2:00 - 30:00	2200lbs. 999kg	264ft ³ 7.39m ³
PS640-3	121.5" 3084mm	27sq.ft. 2.511m ²	76-1/2" 1943mm	1x32" (813mm) or 2x15" (381mm)	76-1/2" 1943mm	78-11/16" 1999mm	60" 1537mm	600°F 315°C	2:00 - 30:00	3300lbs. 1498kg	396ft ³ 11.09m ³

ELECTRICAL SPECIFICATIONS

Version	Voltage	Phase	Freq	Current Draw	Supply	Breakers
USA & std export	208-240v	1	50/60Hz	4.5 Amp-Run 10 Amp-Start	3 wire (2 hot, 1 ground)	As per local codes
Europe (CE)	220-230v	1	50/60Hz	4.5 Amp-Run 10 Amp-Start	3 wire (2 hot, 1 ground)	As per local codes

* The current draw rating shown above are maximum values for normal operation, amperage draw will be less than the listed value.
NOTE: Each oven includes a 6' cord with NEMA# L6-20P plug. Customer to provide NEMA# L6-20R receptacle

INCOMING GAS SUPPLY SPECIFICATIONS

Version	Gas Type	North America	IE,IT,PT,ES,GB II _{2H3+}	DE II _{2ELL3B/P}	NL II _{2L3B/P}	BE, FR II _{2E+3+}	AT,CH,DK,FI,SE II _{2H3B/P}	Rated Heat Input
USA & std. export	Natural Gas	6-8" W.C. (14.9-20.0mbar)	-	-	-	-	-	99,000BTU (29.14kW-hr)
USA & std. export	Propane Gas	11-14" W.C. (27.4-34.9mbar)	-	-	-	-	-	99,000BTU (29.14kW-hr)
Australia Only	Natural Gas	6-8" W.C. (14.9-20.0mbar)	-	-	-	-	-	120,000BTU (126.6MJ)
Australia Only	Propane Gas	11-14" W.C. (27.4-34.9mbar)	-	-	-	-	-	120,000BTU (126.6MJ)
Europe (CE)	G20	-	20mbar	20mbar	-	20-25mbar	20mbar	29.14kW-hr
Europe (CE)	G25	-	-	20mbar	25mbar	-	-	29.14kW-hr
Europe (CE)	G20, G25	-	20mbar	20mbar	25mbar	20-25mbar	20mbar	29.14kW-hr
Europe (CE)	G30	-	29-37mbar	-	28-30mbar	29-37mbar	50mbar	29.14kW-hr
Europe (CE)	G30, G31	-	-	50mbar	30mbar	-	50mbar	29.14kW-hr

The required gas supply pressures of other locations are dependent on the local gas type and on all applicable local codes.

Minimum Gas Pipe Sizes:

* Natural Gas - 2" (51 mm) main supply line. One 3/4" (19mm) NPT branch per oven cavity with individual full-flow shutoff valve.

* Propane Gas - 1 1/2" (31.8 mm) main supply line. One 3/4" (19mm) NPT branch per oven cavity with individual full-flow shutoff valve

NOTE: Each oven includes (1) 3/4"(19mm)NPT x 48"(1219mm) flexible, vinyl coated gas hose.

ALL SPECIFICATIONS SUBJECT TO CHANGE WITHOUT NOTICE.