



Principle

Middleby Marshall PS Series conveyor ovens bake both faster and at a lower temperature than other ovens. Vertical columns of hot air move heat aerodynamically instead of using high temperatures. The streams of hot air remove the boundary layers of cool heavy air which tend to insulate the product. All Middleby ovens are designed to cook a multitude of products including pizza, seafood, sandwiches, bagels, ethnic foods and more.

General Information

The PS528 conveyor oven is ideally suited for Kiosk and express-style locations where smaller ovens are required.

Standard Features

- Patented EMS Energy Management System* reduces gas consumption and increases cooking efficiency
- 28" (711mm) long cooking chamber with 18" (457.2mm) belt
- 50" (1270mm) long, 40-3/4" (1035mm) deep, and 21-3/4" (552.4mm) high overall dimensions
- Furnished with 4" (101.6mm) legs
- Stackable up to three high.
- Microprocessor-controlled bake time/conveyor speed
- Stainless steel front, sides, top and interior
- Reversible conveyor direction
- 12" (304.8mm) Extension Tray
- 15" (381mm) wide front window

Optional Features

- Large legs with casters
- Extended warranty available
- 6" (152.4mm) Extension Tray

Conserves Energy

Unit incorporates a patented Energy Management System - EMS. Middleby ovens provide very efficient heat transfer to product. Energy is conserved as air is recycled from heater to product, with minimum loss. Oven is cool to the touch.

Cleanability

PS528 Ovens are designed for easy cleaning. Removable parts include: crumb pans, end panels, air fingers, exit tray, and a removable conveyor belt assembly.

Easily Services

Control compartment is designed for quick and easy access.

Warranty

All PS528 models have a one year parts and labor warranty.

Ventilation

Use of a ventilation hood is required.



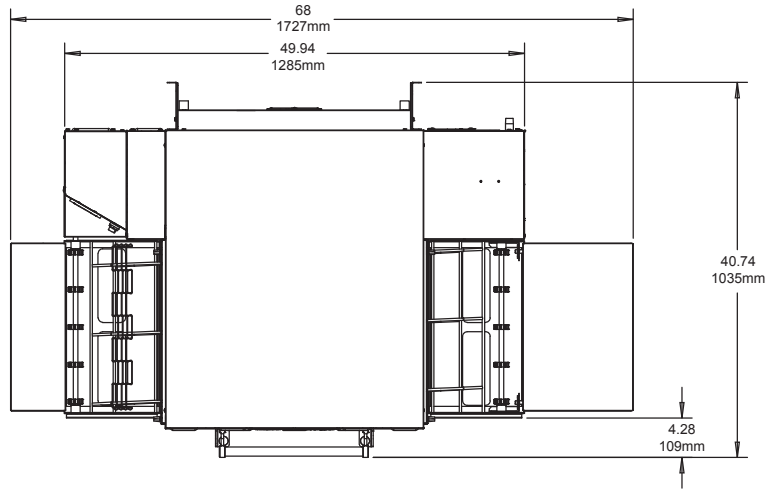

PS528-1

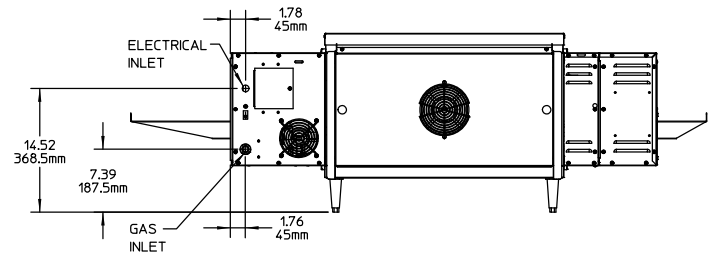
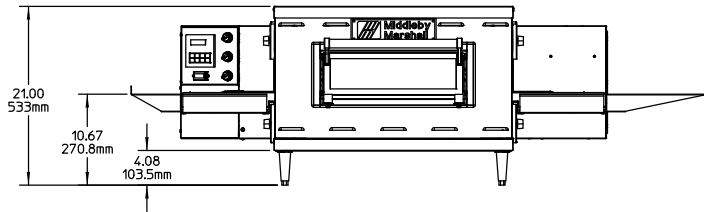

PS528-2

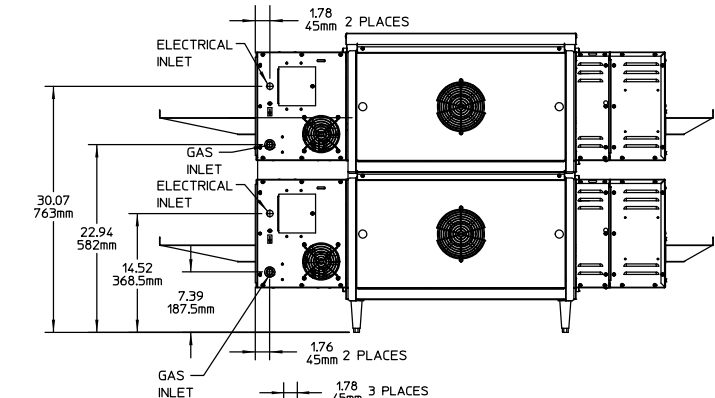
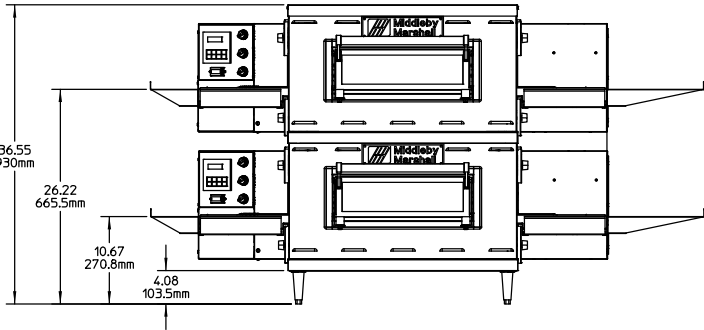

PS528-3

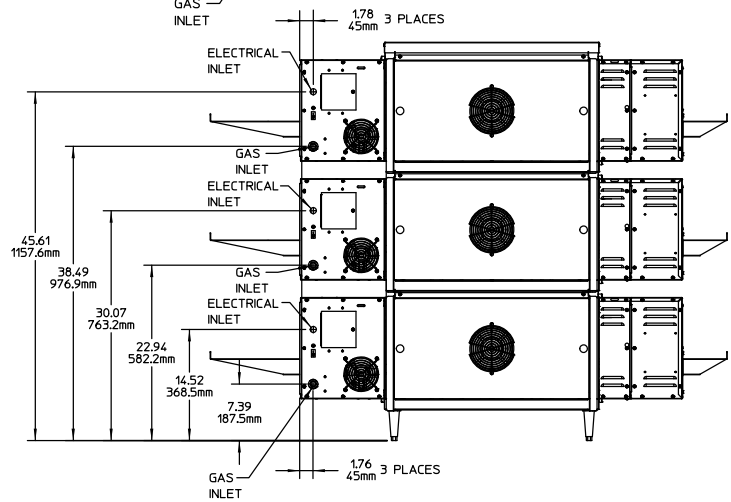
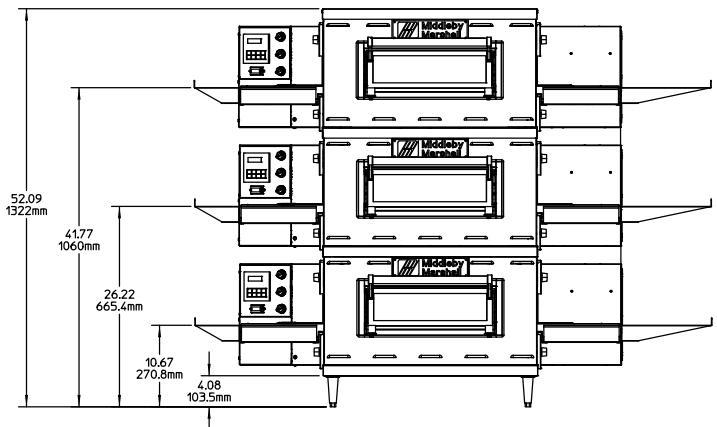

PS528-1 with Optional Legs

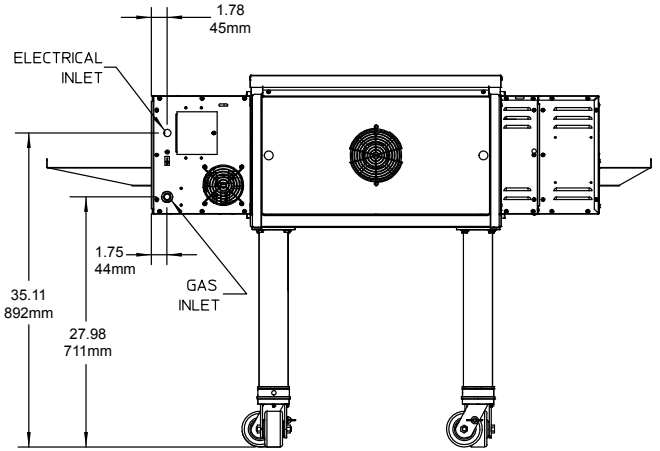
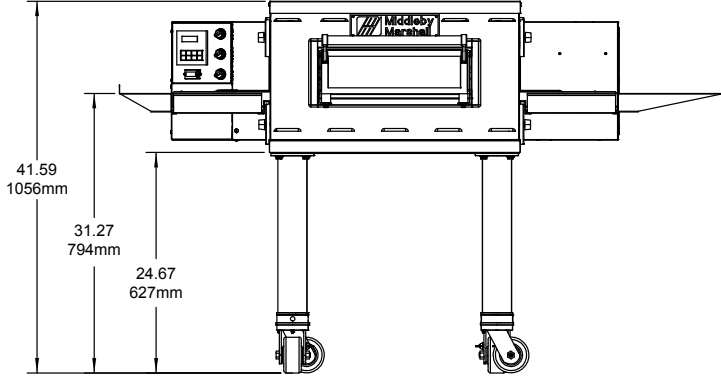

PS528-2 with Optional Legs

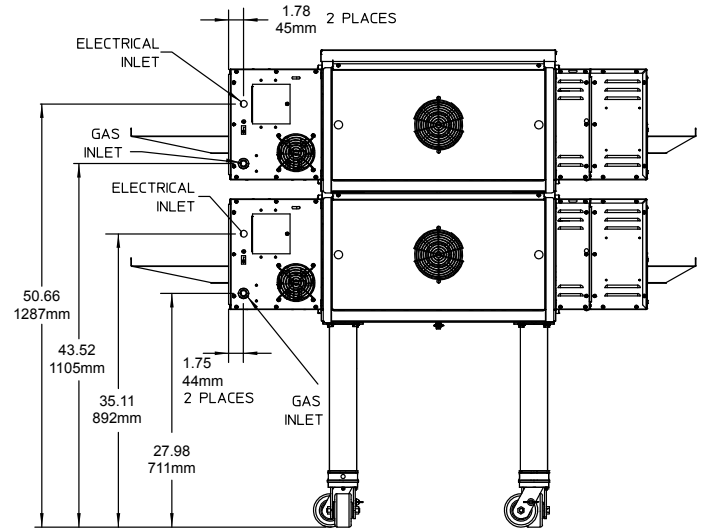
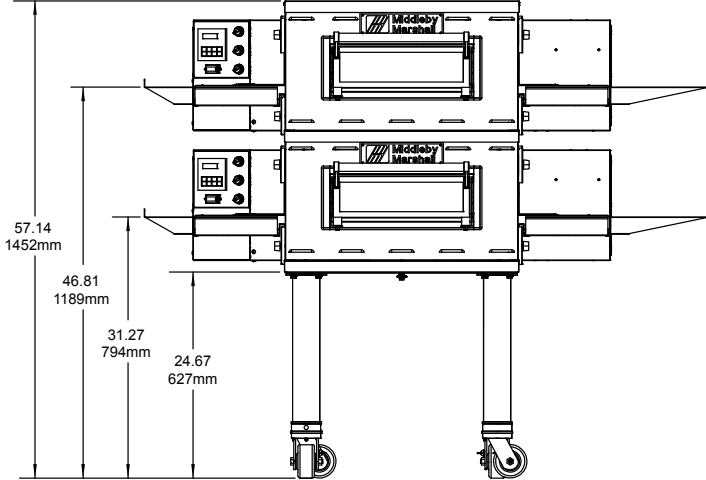

PS528-3 with Optional Legs

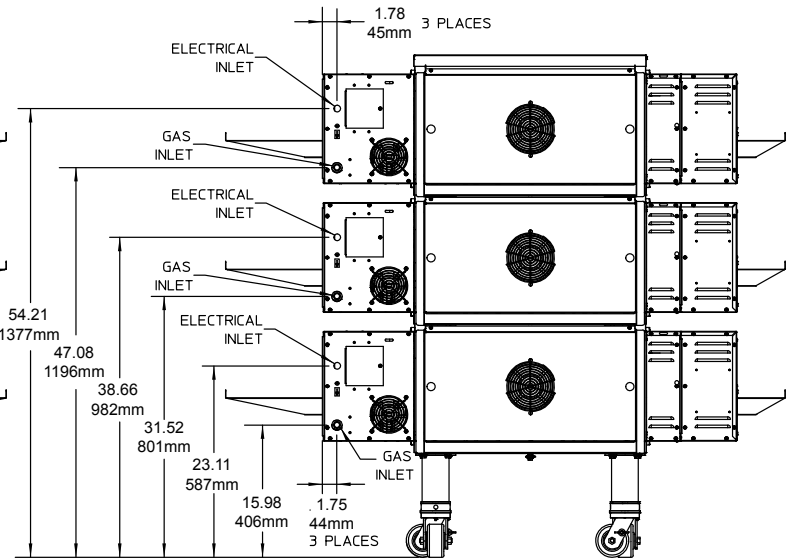
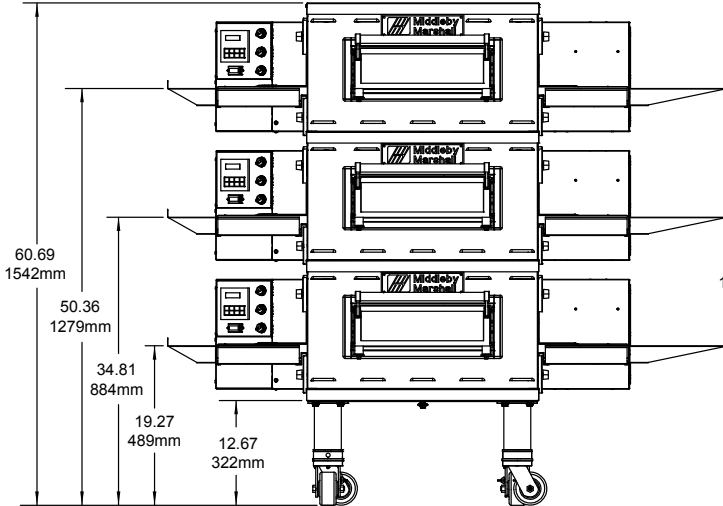

RECOMMENDED MINIMUM CLEARANCES

Rear of Oven to Wall	Control end of conveyor to wall	Non-control end of conveyor to wall
0" (0mm)	0" (0mm)	0" (0mm)

GENERAL SPECIFICATIONS

	Heating Zone	Baking Area	Belt Length	Belt Width	Overall Length exit trays installed	Height 4" legs installed	Depth	Maximum Operating Temp	Bake Time Range	Ship Wt	Ship Cube
PS528-1	28" 711mm	3.5 ft ² 0.33 m ²	50" 1270mm	18" 457mm	68" 1727mm	21.00" 533mm	40.74" 1035mm	600°F 316°C	1-30 min	325lbs 147.42kg	22.1ft ³ 0.62m ³
PS528-2	56" 1422mm	7 ft ² 0.66m ²	50" 1270mm	18" 457mm	68" 1727mm	36.55" 930mm	40.74" 1035mm	600°F 316°C	1-30 min	650lbs 294.48kg	44.2ft ³ 4.25m ³
PS528-3	84" 2133mm	12.25 ft ² 0.99 m ²	50" 1270mm	18" 457mm	68" 1727mm	52.09" 1322mm	40.74" 1035mm	600°F 316°C	1-30 min	975lbs 442.25kg	66.3ft ³ 1.86m ³

ELECTRICAL SPECIFICATIONS

Version	Voltage	Phase	Freq	Current Draw	Supply	Breakers
Domestic and std. export	208/240v	1	50/60 hz	2.0 Amp	2 pole, 3 wire	As per local codes

* The current draw rating shown above are maximum values for normal operation, amperage draw will be less than the listed value.
NOTE: Each oven includes a 6 ft cord with NEMA# L6-20P plug. Customer to provide NEMA# L6-20R receptacle.

GAS SUPPLY SPECIFICATIONS

Version	Gas Type	Supply (inlet) Pressure	Regulated Pressure	Rated Heat Input
Domestic & std export	Natural Gas	6-8" W.C. (14.9-19.9mbar) *	3.5" W.C. (8.72mbar)	50,000 BTU
Domestic & std export	Propane Gas	11-14" W.C. (27.4-34.9mbar) *	10" W.C. (24.9 mbar)	50,000 BTU

* The required gas supply pressures of other locations are dependent on the local gas type and on all applicable local codes.

Minimum Gas Pipe Sizes:

* Natural Gas - 1 1/2" (50.8 mm) main supply line. One 3/4" (19mm) NPT branch per oven cavity with individual full-flow shutoff valve.
 * Propane Gas - 1 1/2" (31.8 mm) main supply line. One 3/4" (19mm) NPT branch per oven cavity with individual full-flow shutoff valve

NOTE: Each oven includes (1) 3/4"(19mm)NPT x 48"(1219mm) flexible, vinyl coated gas hose.

ALL SPECIFICATIONS SUBJECT TO CHANGE WITHOUT NOTICE.