

### HFT Heated Unit

### 33" DEEP HOT FOOD TABLE WITH CURVED FRONT GLASS



HFT67

#### Standard Features

- Curved front glass
- Stainless-steel work counter
- Body white finish
- Lamp with LED light
- Illuminated display area
- Low water level alarm system
- Thermostat heat control
- Additional insulated bottom storage
- Device leveling legs

#### Options

- Other colors available
- Internal frame painted silver or gold
- Straight front glass available

#### Metal elements colors



#### Aluminum profiles colors



#### Dimensions

Model	Dimension W x D x H	Weight (lbs / kg)
HFT35	35 1/2" x 32 1/4" x 47"	132 / 60
HFT51	51 1/4" x 32 1/4" x 47"	154 / 70
HFT59	59" x 32 1/4" x 47"	176 / 80
HFT67	67" x 32 1/4" x 47"	209 / 95
HFT75	76 3/4" x 32 1/4" x 47"	

#### Technical Drawing

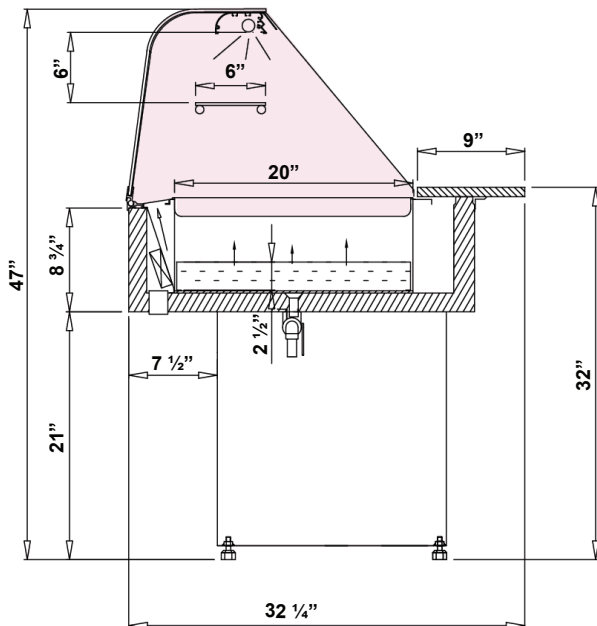

\*\*\*All equipment designed to operate in controlled environment below 75°F (+24°C) temperature and HR 55% relative humidity.

#### Voltage

- HFT35~67 : 115V/220V, 1ph, 60 Hz, 13A, max. fuse: 15A
- HFT75 : 115V/220V, 1ph, 60 Hz, 20A, max. fuse: 30A

\* Specifications are subject to change without notice.

\*\*All measurements are approximates.