

The Inferno WG is a gas-fired rotisserie that allows wood logs to be burned, adding a smokey aroma to roasted foods. As a showpiece that looks best enclosed behind a facade of stone, brick or tile, the WG is generally placed in a restaurant dining room or on display in open-kitchen concepts and upscale supermarket Deli's. The Inferno WG creates an enticing ambiance with its captivating theater and it cooks food to its succulent best.



Smokey Aroma

Wood-burning capability adds a savory flavoring (such as mesquite, hickory or maple) to the food while creating an alluring aroma in the area around the machine.

Effective Impulse Sales Generator

The sight, sound and smell of product roasting over an open flame will captivate customers.

Easy Cleaning

Integrated water pan catches grease drippings to facilitate the cleaning.

Reliable Operation

Years of field experience and advanced R&D capabilities make our equipment among the most reliable on the market.

Customizable Installation

The WG is meant to be enclosed in a structure or behind a facade of your creation. Several examples below show what materials and looks can be achieved.



The Inferno WG is delivered to customers without a facade (left image). Customers have the option to install their own facades. The 3 images to the right are samples.

You can also cook...

Eye of Round Roast



Salmon Steaks



Ribs



Pork Loin



For the full list of recipes, please contact us

INFERNO WG

Specifications

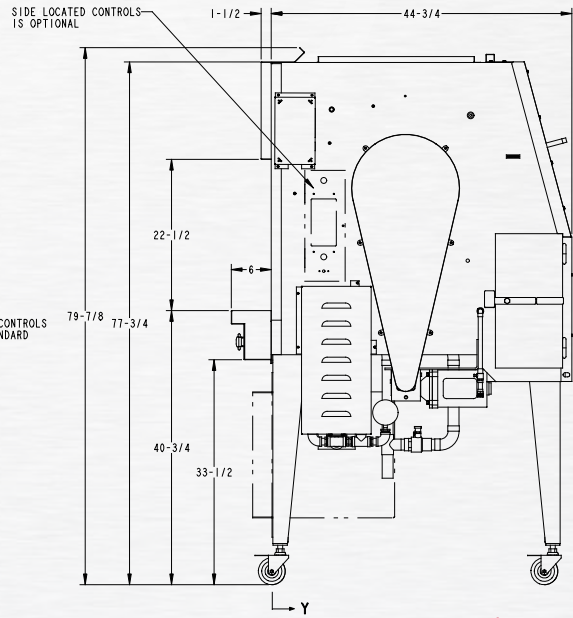
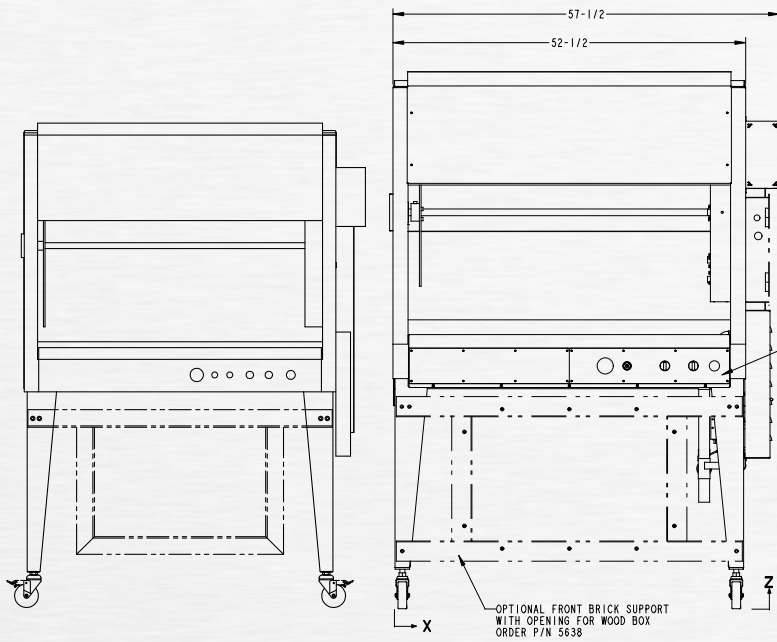

ref 99-8098

* Left-hand configuration also available

* Shown with optional casters

Installation

Connections (right-hand model)	X Position	Y Position	Z Position
Drain / Overflow Ø 1.5" copper	46¼ In [1174] mm	17¼ In [438] mm	16 In [406] mm
Drain Valve	46¼ [1174]	22 [559]	23¼ [591]
Electrical: 120VAC, 7.5 AMP, 60 Hz, single phase (3-prong 6' cord)	46¼ [1175]	9¾ [248]	25¼ [641]
Gas 3/4 NPT Male	46¼ [1175]	9¾ [248]	21¼ [540]

Requirements:

- Natural Gas
 - Minimum supply pressure: 7" W.C.
 - Manifold pressure: front: 5" W.C., rear: 5" W.C.
- Propane Gas
 - Minimum supply pressure: 11" W.C.
 - Manifold pressure: front: 10" W.C., rear: 10" W.C.
- Rotisserie must vent freely under a canopy hood hung 84" min. above the floor. The recommended CFM is 1750. Hood must overhang rotisserie by 12" min. in the front, 0" min. (flush) in the back and 6" min. on each side.
- Required clearances:
 - Front: 36" minimum (for operations)
 - Rear: 4" minimum to combustibles
 - Right: 4" minimum to combustibles (24" required for servicing)
 - Left: 4" minimum to combustibles
- Drain connection can be configured to drain to either a bucket, grease separator or floor drain

Specification & Options

Nominal Gas Consumption	140,000 BTU / hr for natural gas 140,000 BTU / hr for propane gas	
Capacity	up to 48 chickens	
Warranty	2 Years Parts & Labor	
Construction	Primarily stainless steel	
Included Accessories	<ul style="list-style-type: none"> 8 "V" skewers Stoker & poker set Stainless steel shelf Drain strainer Gas pressure gauge 	<ul style="list-style-type: none"> Height-adjustable legs Fire suppression pipes Basic plumbing hardware Thermometer Owner's manual
Options	<ul style="list-style-type: none"> Front brick support Custom water inlet Side control panel configuration Wood box 	<ul style="list-style-type: none"> Custom drain configuration Hold mode Left-hand drive configuration Casters

Available Accessories

Part Name	Description	Picture
"V" skewers	Supports the chicken but does not pierce the skin, retaining the natural juices that give the bird flavor.	
Roast Skewer	Designed to hold large cuts of meat, roasts and large whole turkeys without piercing the meat. Note: every other slot on the drive must be skipped when using this skewer.	
Hanging Basket	Designed for products that should not rotate during cooking, the basket stays flat as the drive turns.	
Rib Basket	A clamshell basket that is ideal for cooking ribs, chicken parts and a variety of other roasts.	

Contact us for the full list of available accessories.