

## Dough Sheeter, Countertop MODEL: DL18SP



### FEATURES & BENEFITS

- Compact Design
- Minimum Roller Gap - 1/32" (0.79 mm)
- Maximum Roller Gap - 5/32" (3.9 mm)
- Able to Handle Up to a 18" Product (305 mm)
- Sheet up to 600 pieces per hour (Based on Operator & Product)
- Adjustable Roller Gap
- Stainless Scraper for Rollers
- Teflon Rollers
- Sealed Bearings
- Stainless Steel Infeed & Chute
- 1/2 HP Motor
- Designed for use with 1 - 10 1/2 oz dough portions

### OPTIONS

- Foot Pedal
- CSST Conformity Kit for Quebec
- International Electrical Configuration (208-240V/1 ph)

### ELECTRICAL

#### Single Phase

- 120 V - 60 hz - 0.7 kW - 6 Amps - Nema 5-15P
- 208 V - 50/60 hz - 0.7 kW - 3.4 Amps - 2 Wires + Ground
- 240 V - 50/60 hz - 0.7 kW - 3 Amps - 2 Wires + Ground

### FINISH

Stainless Steel

### STANDARD PRODUCT WARRANTY

One Year Parts & Two Year Labor

### DRAWINGS

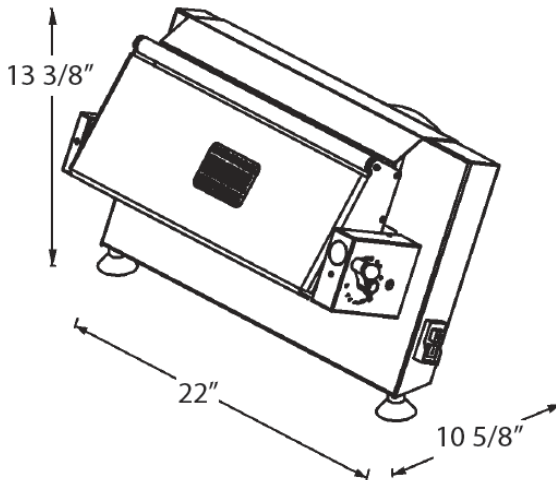

### RECOMMENDED USAGE

- Products at room temperature
- Dough Products between 50-60% Hydration Only
- Not designed for fondant or laminated dough products
- Ideal for Pizza, Cookies, Pie Crusts, Flat Breads, Wraps, etc.

### DIMENSIONS & WEIGHT

22" W x 10 5/8" D x 13 3/8" H  
(559 mm x 271 mm x 340 mm)  
100 lbs (45 kgs)

### SHORT SPECIFICATION

Dough Sheeter, Countertop, Electric, Stainless Steel Construction, Light Weight, Resin Constructed Rollers, Stainless Steel Scrapers, Adjustable Rollers, Minimum Roller Gap of 1/32", Maximum Roller Gap of 5/32", One Year Labor & Two Year Parts Warranty