



181GW
High Temperature
Undercounter Glasswasher



MODEL CMA 181GW

FEATURES:

- **Energy Star Approved.**
- 16 gauge 304 Stainless Steel wash tank.
- 30 racks per hour or 600 glasses per hour (20 per 19-3/4"X19-3/4" rack).
- .75 gallons of water per cycle or rack.
- Safe-T-Temp booster heater capable of a 70°F rise. (3 minute cycle)
- 180°F final rinse
- Detergent and rinse chemical pumps.
- Fresh water rinse through upper and lower rotating arms.
- Removable Stainless Steel pump protection screen for easy cleaning.
- Raised wash chamber reduces "bending over" to remove racks
- Gravity drain system.
- **Great application for the WINE industry.**



Top mounted controls are easy to read and simple to operate.



6" legs for increasing the overall height to 40" is standard.



Large 11-1/4" height clearance accommodates larger glassware.

Options Available: CMA 181GW

- Stainless Steel Pedestal
- 4 Inch legs Part # 1146.50 (4 needed)
- Pump Drain Kit Part # 15502.50





181GW

High Temperature
Undercounter Glasswasher

WARNINGS:

- Plumbing connections must be made by a qualified service company who will comply with all available Federal, State, and Local Health, Plumbing and Safety codes.
- Water hardness above 3 grains per gallon should be treated by a water softener. Failure to provide soft water (3g or less) will void the machine warranty.

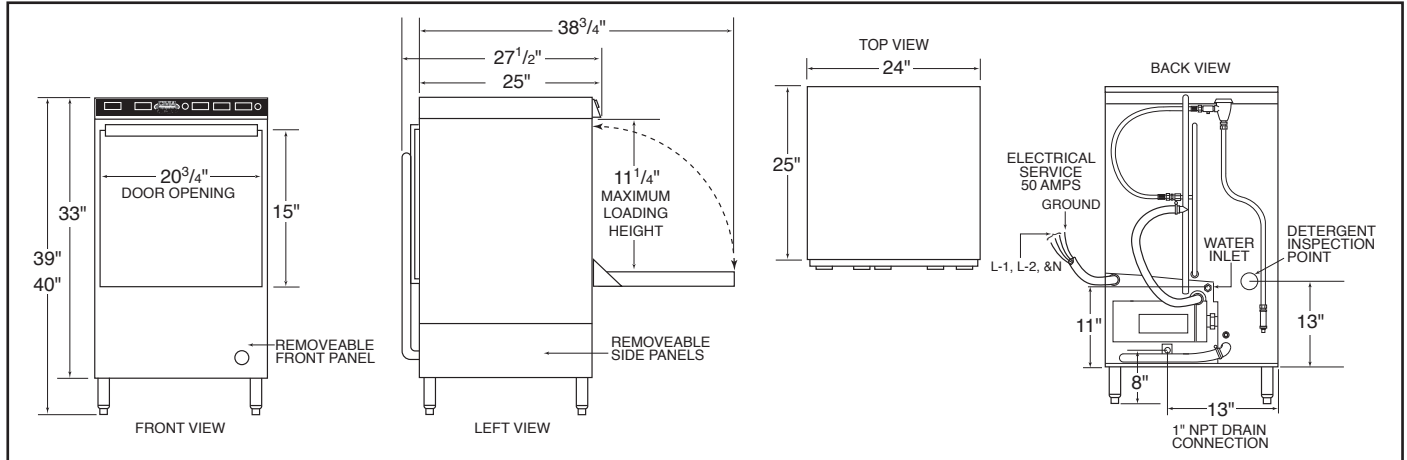

Specifications:

CMA-181GW	USA	(Metric)	CMA-181GW	USA	(Metric)
WATER CONSUMPTION			FRAME DIMENSIONS		
PER RACK	.75 GAL.	(2.84 L)	DEPTH	25"	(63.5 CM)
PER HOUR	18 GAL.	(68.1 L)	WIDTH	24"	(60.96 CM)
OPERATING CYCLE			HEIGHT	39"-40"	(99-101.6 CM)
WASH TIME-SEC	94	94	MAX CLEARANCE FOR DISHES	11-1/4"	(28.6 CM)
RINSE TIME-SEC	16	16	WASH PUMP MOTOR	1 HP	1 HP
DWELL TIME-SEC	10	10	ELECTRICAL RATING	208 VOLTS	230 VOLTS
TOTAL CYCLE TIME	2 MIN.	2 MIN.		1 PH-60 Hz	1 PH-60 Hz
OPERATING CAPACITY			TOTAL AMPS	33.0 AMPS	35.0 AMPS
RACKS PER HOUR	30	30	BOOSTER HEATER KW	5.3 KW	6.5 KW
WASH TANK CAPACITY	2.5 GAL.	(9.46 L)	THIS SYSTEM REQUIRES THREE POWER WIRES WHICH INCLUDES A CURRENT CARRYING NEUTRAL. AN ADDITIONAL FOURTH WIRE MUST BE PROVIDED FOR MACHINE GROUND.		
PUMP CAPACITY	38 GPM	(144 LPM)			
WATER REQUIREMENTS			SHIPPING WEIGHT		
REQUIRED MINIMUM TEMP.*	110°F	(43°C)	APPROXIMATE	234#	(106 KG)
RECOMMENDED TEMP.**	140°F	(60°C)	*For machine having "Safe-T-Temp"		
WATER INLET	1/2"	(1.27 CM)	**For faster heat recovery		
DRAIN CONNECTION	1"	(2.54 CM)			
RINSE PRESSURE SET	20 ± 5PSI	1.41 KG/CM²			
CYCLE TEMPERATURES					
WASH-°F	155° F-160° F	(68.3°C/71°C)			
RINSE-°F	180° F-195° F	(82°C/90°C)			

Summary Specifications: CMA 181GW

The CMA 181GW undercounter dishwasher provides hot water (180°F) sanitizing through the use of a built-in booster heater. 180°F final rinse safety system ensures proper temperatures in the final rinse by holding wash cycle in run mode until 180°F rinse temperature is detected. The unit comes standard with upper and lower stainless steel wash and final rinse arms, digital LED temperature gauges and easy to operate controls. The CMA 181GW is constructed entirely of stainless steel. Uses standard 19-3/4"X19-3/4" glassracks with a 11-1/4" door clearance.

Advisory: CMA does NOT endorse "Tankless On-Demand" water heaters for use on CMA Dishmachine products. CMA DOES endorse, and highly recommends, the standard "tank" style water heaters, sized properly to handle each particular facility with their water heating requirements.

