



180UC
High Temperature
Undercounter Dishwasher



FEATURES:

- **Energy Star Qualified.**
- The 2 minute timer includes the built-in, automatic Safe-T-Temp feature, which assures a 180°F sanitizing final rinse, every cycle.
- Patented automatic soil purging system. Filters wash water and traps plate debris in an external drawer. Drawer can be easily removed for dumping contents.
- Upper and lower rotating wash and rinse arms provide excellent cleaning and rinsing.
- All stainless steel construction, no plastic parts to repair.
- Patented built-in booster heater. Economical, single source heat lowers energy costs.
- Large 14-1/2" height clearance accommodates larger dishes and half size sheet pans.
- Low water consumption. Uses only .75 gallons of water per cycle.
- Pumped drain.
- All Stainless Steel wash pump.



Top mounted controls are easy to read and simple to operate.

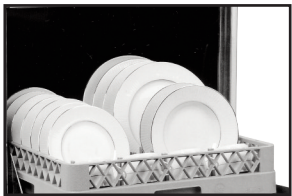

Large 14-1/2" height clearance accommodates larger dishes and half size sheet pans.

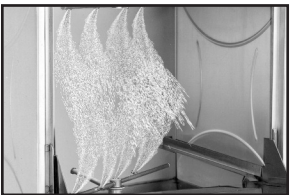

Upper and lower rotating wash and rinse arms blast water in all directions for optimum cleaning and rinsing.



Soil purging system keeps the wash water clean assuring excellent results while reducing chemical costs.

Available Options

- 48" Undercounter Dishtable
- Built-in Rinse pump
- Detergent and Rinse Pump
- Stainless Steel Pedestal
- 4/6 Inch legs (4 needed)
- Delimer Switch Kit
- Water Tempering Kit





180UC

High Temperature Undercounter Dishwasher

WARNINGS:

- Plumbing connections must be made by a qualified service company who will comply with all available Federal, State, and Local Health, Plumbing and Safety codes.
- Water hardness above 3 grains per gallon should be treated by a water softener. Failure to provide soft water (3g or less) will void the machine warranty.

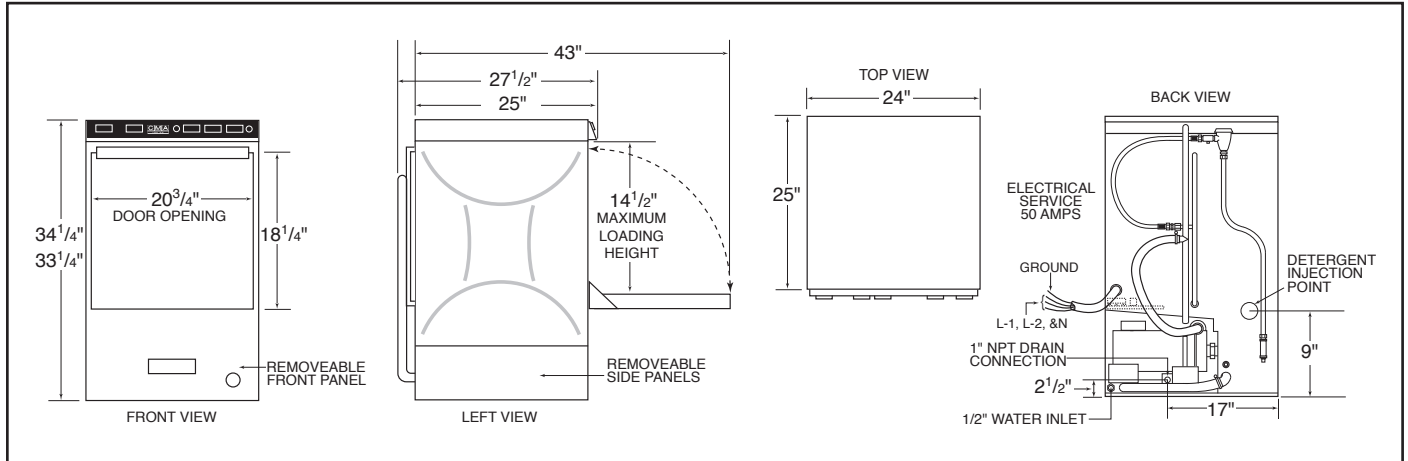

Specifications:

CMA-180UC	USA	(Metric)	CMA-180UC	USA	(Metric)
WATER CONSUMPTION			FRAME DIMENSIONS		
PER RACK	.75 GAL.	(2.84 L)	DEPTH	25"	(63.5 CM)
PER HOUR	18 GAL.	(68.1 L)	WIDTH	24"	(60.96 CM)
OPERATING CYCLE			HEIGHT	33-1/4"	(84.45 CM)
WASH TIME-SEC	94	94	MAX CLEARANCE FOR DISHES	14-1/2"	(36.8 CM)
RINSE TIME-SEC	16	16	WASH PUMP MOTOR		
DWELL TIME-SEC	10	10		1 HP	1 HP
TOTAL CYCLE TIME	2 MIN.	2 MIN.	ELECTRICAL RATING		
OPERATING CAPACITY			TOTAL AMPS	208 VOLTS	230 VOLTS
RACKS PER HOUR	30	30	BOOSTER HEATER KW	1 PH-60 Hz	1 PH-60 Hz
WASH TANK CAPACITY	2.5 GAL.	(9.46 L)		33.0 AMPS	35.0 AMPS
PUMP CAPACITY	38 GPM	(144 LPM)		5.3 KW	6.5 KW
WATER REQUIREMENTS			THIS SYSTEM REQUIRES THREE POWER WIRES (SUPPLIED BY CMA) WHICH INCLUDES A CURRENT CARRYING NEUTRAL. AN ADDITIONAL FOURTH WIRE MUST BE PROVIDED FOR MACHINE GROUND.		
REQUIRED MINIMUM TEMP.*	110°F	(43°C)			
RECOMMENDED TEMP.**	140°F	(60°C)			
WATER INLET	1/2"	(1.27 CM)			
DRAIN CONNECTION	1"	(2.54 CM)			
RINSE PRESSURE SET	20 ± 5PSI	1.41 KG/CM²	SHIPPING WEIGHT		
CYCLE TEMPERATURES			APPROXIMATE	234#	(106 KG)
WASH-°F	155° F-160° F	(68.3°C/71°C)	**For machine having "Safe-T-Temp"		
RINSE-°F	180° F-195° F	(82°C/90°C)	**For faster heat recovery		

Summary Specifications: CMA-180UC

The CMA Energy Miser model CMA-180UC undercounter dishwasher provides hot water (180°F) sanitizing through the use of a built-in booster heater. 180°F final rinse safety system ensures proper temperatures in the final rinse by holding wash cycle in run mode until 180°F rinse temperature is detected. The unit comes standard with upper and lower stainless steel wash and final rinse arms, digital LED temperature gauges and easy to operate controls. The CMA-180UC incorporates an automatic soil purging system uniquely designed (patent pending) into the wash tank that enables the wash water to remain clean, assuring excellent results and less chemical use. The CMA-180UC is constructed entirely of stainless steel. Uses standard 20"X20" dishracks and accommodates oversized plates and utensils with a 14-1/2" door clearance.

Advisory: CMA does NOT endorse "Tankless On-Demand" water heaters for use on CMA Dishmachine products. CMA DOES endorse, and highly recommends, the standard "tank" style water heaters, sized properly to handle each particular facility with their water heating requirements.

