

1200-TH/III MARINE

Low Temperature Electronic Cook & Hold Oven

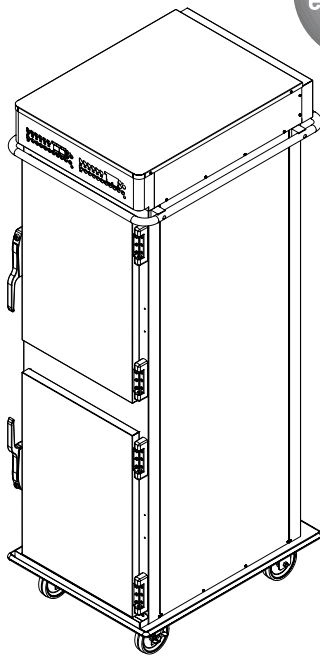

- Halo Heat . . . a controlled, uniform heat source that maintains close temperature tolerances throughout the cooking and holding function. Offers uniform and consistent cooking on a daily basis, low shrinkage of bulk or portion-cut protein items, higher food moisture content, and significantly longer holding life.
- Cooks, roasts, re-heats, and holds in the same cabinet with set-and-forget controls to provide a better distribution of work loads.
- Cooks by time or by probe to sense internal product temperature and automatically converts from cook mode to hold mode once the set parameters have been reached.
- Oven hoods, outside venting, and fire extinguisher systems are not required (IN MOST AREAS). Emission of grease laden air are less than U.L. established standards.
- Eight programmable menu buttons stores favorite recipes into memory (COOK/HOLD/TIME/PROBE SET-POINTS). Reduces operational requirements to simply loading the oven, pushing the power button, the preset menu button, and start.
- Clear, easy-to-read LED display indicates cook time remaining or the full range of programmed operating parameters.
- When cooking by probe, the oven maintains a record of the highest and lowest temperatures sensed by the food probe to assure foods are cooked to the temperature required.
- Oven includes the patented SureTemp™ heat recovery system to assure immediate compensation for any heat loss whenever the door is opened and provides an audible reminder if the door has been left open for more than three minutes.

Short Form Spec

Alto-Shaam double compartment 1200-TH/III Cook & Hold oven is constructed with a non-magnetic stainless steel exterior and non-magnetic stainless steel doors, each with a magnetic door latch. Each compartment is equipped with two (2) stainless steel side racks with eight (8) pan positions spaced on 2-15/16" (75mm) centers, three (3) stainless steel wire shelves, and one (1) stainless steel drip pan with drain. Oven includes one (1) external drip tray and one (1) set of 3" (76mm) heavy duty casters — 2 rigid, and 2 swivel with brake.

The oven features two (2) deluxe controls, one for each compartment. Each control consists of a 4-digit LED display, ON/OFF button, cook temperature button with an adjustable cook range from 200°F to 325°F (93°C to 162°C), time control button with set-points from 1 minute to 24 hours, probe control button with adjustable set-points between 50°F and 195°F (10°C to 91°C), and hold temperature button with an adjustable hold range from 60°F to 205°F (15°C to 96°C). Each control includes eight (8) programmable menu buttons with the ability to set individual cook and hold parameters, hold mode count-up timer, operation status indicator lights, and start button. The controls have a built-in lock out feature. The oven is equipped with a voltage conversion feature to match the line voltage provided by the electric power supplier.

- 1200-TH/III Marine (Standard):** Double compartment Cook & Hold oven with two (2) deluxe controls and two (2) cords.
- 1200-TH/III Marine (Optional):** Double compartment Cook & Hold oven with one (1) deluxe control and one (1) cord.

Specify single control, single cord at time of purchase.

Factory-Installed Options

- Door Swing
 - Right-hand swing, standard
 - Left-hand swing, optional
- Temperature scale
 - Fahrenheit, standard
 - Celsius, optional
- Push handles (HD-26792)
 - Order four (4) push handles

**Lifetime
Warranty**

On all Cook & Hold heating elements (EXCLUDES LABOR).



W164 N9221 Water Street • P.O. Box 450 • Menomonee Falls, Wisconsin 53052-0450 • U.S.A.
Phone: 262.251.3800 800.558.8744 U.S.A./CANADA Fax: 262.251.7067 800.329.8744 U.S.A. only
www.alto-shaam.com

1200-TH/III MARINE

Low Temperature Electronic Cook & Hold Oven

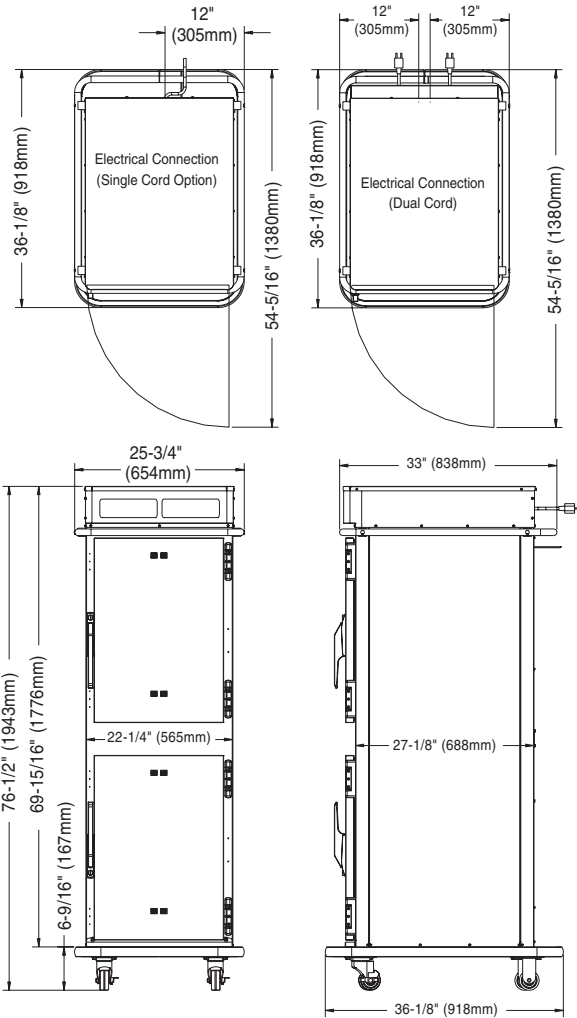

Dimensions: H x W x D
Exterior: 76-1/2" x 25-3/4" x 36-1/8" (1943mm x 654mm x 918mm)
Interior per compartment: 26-7/8" x 18-7/8" x 26-5/8" (682mm x 479mm x 676mm)

Electrical					
V	Ph	Hz	A	kW	Cord and plug
Single cord					
230V	1	50/60	23	5.3	Cord, no plug
Double cord					
230V	1	50/60	23	5.3	CEE 7/7, 220-230V plug
Per cord/compartment:			12	2.7	

Product/Pan Capacity (per compartment)	
120 lb (54 kg) maximum Volume maximum: 60 quarts (76 liters)	
Eight (8)	Full-size pans: 20" x 12" x 2-1/2" (530mm x 325mm x 65mm) Gastronorm 1/1:
Eight (8)	Full-size sheet pans: 18" x 26" x 1"

Clearance Requirements		Installation Requirements	
Rear	3" (76mm) from non-heated surfaces 18" (457mm) from heat producing equipment	<ul style="list-style-type: none"> – Oven must be installed level. – The oven must not be installed in any area where it may be affected by steam, grease, dripping water, extreme temperatures, or any other severely adverse conditions. – A flexible connector must be installed and secured to the building structure. Not factory supplied. 	
Top	2" (51mm)		
Left, Right	1" (25mm)		
Weight			
Net: 420 lb (191 kg) Est.	Ship: 586 lb (266 kg)		
Carton dimensions: (L x W x H) 39" x 41" x 84" (991mm x 1041mm x 2134mm)			

Accessories			
Carving holders		<input type="checkbox"/> Push handles (factory installation only)	HD-26792
<input type="checkbox"/> Prime rib	HL-2635	<input type="checkbox"/> Legs, flanged, 6" (152mm)	LG-23067
<input type="checkbox"/> Steamship (cafeteria) round	4459	<input type="checkbox"/> Pan grid, wire, 18" x 26" sheet pan insert	PN-2115
<input type="checkbox"/> Door lock with key	LK-22567	<input type="checkbox"/> Rib rack, stainless steel	SH-29474
<input type="checkbox"/> Drip pan, extra deep	13162	<input type="checkbox"/> Shelf, stainless steel, flat wire	SH-2325
<input type="checkbox"/> Drip pan, extra deep with drain	4932		



W164 N9221 Water Street • P.O. Box 450 • Menomonee Falls, Wisconsin 53052-0450 • U.S.A.
 Phone: 262.251.3800 800.558.8744 U.S.A./Canada Fax: 262.251.7067 800.329.8744 U.S.A. only
 www.alto-shaam.com