



TRUE FOOD SERVICE EQUIPMENT, INC.

2001 East Terra Lane • O'Fallon, Missouri 63366-4434 • (636)240-2400
 Fax (636)272-2408 • Toll Free (800)325-6152 • Intl Fax# (001)636-272-7546
 Parts Dept. (800)424-TRUE • Parts Dept. Fax# (636)272-9471 • www.truemfg.com

Project Name: _____

A/A #

Location: _____

Item #: _____ Qty: _____

SIS #

Model #: _____

Model:
TPP-93

Food Prep Table:
Solid Door Pizza Prep Table



Scan code for video

TPP-93

- ▶ True's pizza prep tables are designed with enduring quality that protects your long term investment.
- ▶ Oversized, environmentally friendly (R134A) forced-air refrigeration system holds 33°F to 41°F (.5°C to 5°C).
- ▶ Complies with and listed under ANSI/NSF-7.
- ▶ All stainless steel front, top and ends. Matching aluminum finished back.
- ▶ Stainless steel, patented, foam insulated flat lids keep pan temperatures colder, lock in freshness, and minimize condensation.
- ▶ Interior - attractive, NSF approved, clear coated aluminum liner. Stainless steel floor with coved corners.
- ▶ Extra-deep 19½" (496 mm) full length removable cutting board included. Sanitary, high density, NSF approved white polyethylene provides tough preparation surface.
- ▶ Foamed-in-place using a high density, polyurethane insulation that has zero ozone depletion potential (ODP) and zero global warming potential (GWP).

ROUGH-IN DATA

Specifications subject to change without notice.
 Chart dimensions rounded up to the nearest 1/8" (millimeters rounded up to next whole number).

Model	Doors	Shelves	Pans (top)	Cabinet Dimensions (inches) (mm)			HP	Voltage	Amps	NEMA Config.	Cord Length (total ft.) (total m)	Crated Weight (lbs.) (kg)
				L**	D†	H*						
TPP-93	3	6	12	93¼	32¼	35¾	½	115/60/1	9.7	5-15P	7	605
				2369	820	909	½	230-240/50/1	4.2	▲	2.13	275

** Length does not include ¼" (7 mm) each side for cutting board brackets and thumb screws.

† Depth does not include 1" (26 mm) for rear bumpers and 3" (77 mm) for cutting board.

* Height does not include 6¼" (159 mm) for castors or 6" (153 mm) for optional legs.

▲ Plug type varies by country.



APPROVALS:

AVAILABLE AT:

Model:
TPP-93

Food Prep Table: Solid Door Pizza Prep Table



STANDARD FEATURES

DESIGN

- True's commitment to using the highest quality materials and oversized refrigeration systems provides the user with colder product temperatures, lower utility costs, exceptional food safety and the best value in today's food service marketplace.

REFRIGERATION SYSTEM

- Factory engineered, self-contained, capillary tube system using environmentally friendly (CFC free) 134A refrigerant.
- Oversized, factory balanced refrigeration system with guided airflow to provide uniform temperature in food pan rail and cabinet interior.
- Forced-air design holds 33°F to 41°F (5°C to 5°C) product temperature in food pans and cabinet interior. Complies with and listed under ANSI/ NSF-7.
- Condensing unit accessed from behind front removable panel, slides out for easy maintenance.

CABINET CONSTRUCTION

- Exterior - stainless steel front, top and ends. Matching aluminum finished back.
- Interior - attractive, NSF approved, clear coated aluminum liner. Stainless steel floor with coved corners.
- Insulation - entire cabinet structure and solid doors are foamed-in-place using Ecomate. A high density, polyurethane insulation that has zero ozone depletion potential (ODP) and zero global warming potential (GWP).
- 5" (127 mm) diameter stem castors. 36" (915 mm) work surface height.

DOORS

- Stainless steel exterior with white aluminum liner to match cabinet interior.
- Each door fitted with 12" (305 mm) long recessed handle that is foamed-in-place with a sheet metal interlock to ensure permanent attachment.

- Positive seal doors swing within cabinet dimensions.
- Magnetic door gaskets of one piece construction, removable without tools for ease of cleaning.

SHELVING

- Six (6) adjustable, heavy duty PVC coated wire shelves. Two (2) right and two (2) left section shelf dimensions are 23⁵/₁₆" L x 28"D (601 mm x 712 mm). Center door shelf dimensions are C (648 mm x 712 mm). Four (4) chrome plated shelf clips included per shelf.
- Shelf support pilasters made of same material as cabinet interior; shelves are adjustable on 1/2" (13 mm) increments.

MODEL FEATURES

- Evaporator is epoxy coated to eliminate the potential of corrosion.
- Extra-deep 19¹/₂" (496 mm), full length removable cutting board included. Sanitary, high-density, NSF approved white polyethylene provides tough preparation surface.
- Stainless steel, patented, foam insulated flat lids keep pan temperatures colder, lock in freshness, and minimize condensation.
- Refrigerated pan rail comes standard with twelve (1/2 size) 12³/₄" L x 6¹/₄" W x 6"D (324 mm x 159 mm x 153 mm) NSF approved clear polycarbonate insert pans.
- NSF-7 compliant for open food product.

ELECTRICAL

- Unit completely pre-wired at factory and ready for final connection to a 115/60/1 phase, 15 amp dedicated outlet. Cord and plug set included.



115/60/1
NEMA-5-15R

OPTIONAL FEATURES/ACCESSORIES

Upcharge and lead times may apply.

- 230 - 240V / 50 Hz.
- 6" (153 mm) standard legs.
- 6" (153 mm) seismic/flanged legs.
- 4" (102 mm) diameter castors.
- 3" (85 mm) diameter castors.
- 2¹/₂" (64 mm) diameter castors.
- Barrel locks (factory installed). Requires one per door.
- Garnish racks.
- Half bun tray rack. Each holds up to eleven 18"L x 26"D (458 mm x 661 mm) sheet pans (sold separately).
- 19¹/₂" (496 mm) deep, 3/4" (19 mm) thick, white polyethylene cutting board.
- 19¹/₂" (496 mm) deep, 1/2" (13 mm) thick, composite cutting board.
- Half bun tray racks. Holds up to eleven 18"L x 26"D (458 mm x 661 mm) sheet pans (sold separately).
- Exterior round digital temperature display (factory installed).

*CABINET INTERIOR

Beginning in October of 2014, True Manufacturing began the process of changing the standard interior finishes on select products. The interior liners of these units have changed from the traditional NSF-approved white aluminum to an NSF-approved clear coated aluminum that is silver in color. In addition, the traditional white PVC coated shelves have been switched to a gray PVC coating. There are no functional differences created by any of these changes, the difference is only in the appearance. The following product lines are affected by this change: T-Series, TUC, TWT, TSSU, TFP, TPP, TMC, TRCB. A sticker will be placed on the outside packaging so that units with this change can be identified in inventory.

PLAN VIEW

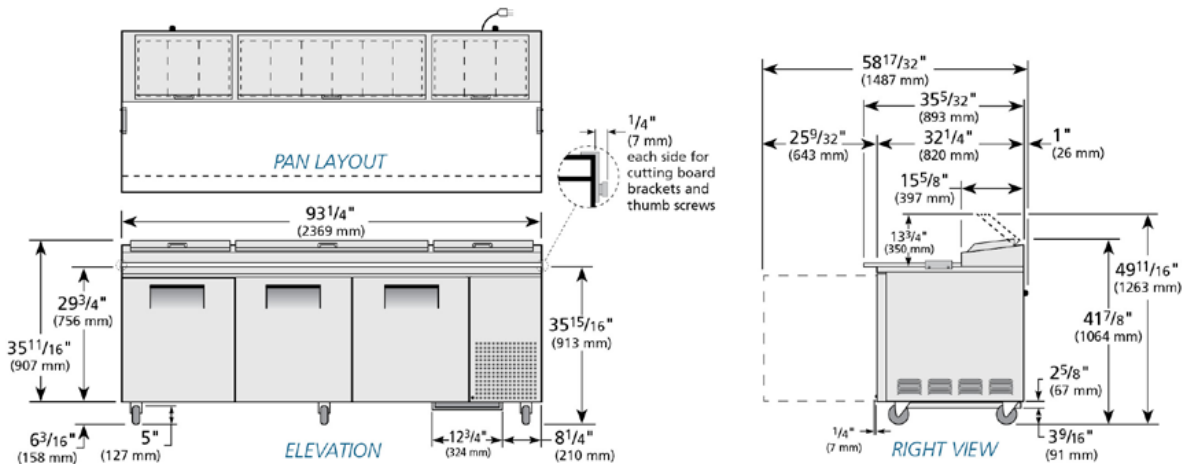

WARRANTY*
Three year warranty on all parts and labor and an additional 2 year warranty on compressor. (U.S.A. only)

METRIC DIMENSIONS ROUNDED UP TO THE NEAREST WHOLE MILLIMETER

SPECIFICATIONS SUBJECT TO CHANGE WITHOUT NOTICE



Model	Elevation	Right	Plan	3D	Back
TPP-93	TFQY12E	TFQY15S	TFQY12P	TFQY123	

TRUE FOOD SERVICE EQUIPMENT

2001 East Terra Lane • O'Fallon, Missouri 63366-4434 • (636)240-2400 • Fax (636)272-2408 • Toll Free (800)325-6152 • Intl. Fax# (001)636-272-7546 • www.truefmfg.com