



TRUE FOOD SERVICE EQUIPMENT, INC.

2001 East Terra Lane • P.O. Box 970 • O'Fallon, Missouri 63366
(636)240-2400 • Fax (636)272-2408 • (800)325-6152 • Intl Fax# (001)636-272-7546
Parts Dept. (800)424-TRUE • Parts Dept. Fax# (636)272-9471 • www.truemfg.com

Project Name: _____

Location: _____

Item #: _____ Qty: _____

Model #: _____

A/A #

SIS #

Model:
TFM-51FL

Horizontal Freezer:
Glass Flat Lid



TFM-51FL

- ▶ True's horizontal freezers are uniquely designed to promote high-profit frozen novelties in high impulse retail traffic areas. Ideal for bolstering incremental sales of frozen merchandise and seasonal specialties.
- ▶ Cold wall, environmentally friendly (134A) refrigeration system. Maintains -10°F (-23.33°C), ideal for both ice cream and frozen food.
- ▶ Exterior - non-peel or chip white laminated vinyl, durable and permanent; with gray mitered plastic top and lid frames.
- ▶ Interior - NSF approved, white aluminum with 300 series stainless steel floor.
- ▶ Tempered, hard coated, "Low-E" glass slide lids. Reduces solar heat gain, enhances energy efficiency and minimizes condensation.
- ▶ Locks standard, provide security, prevents theft.
- ▶ Convenient defrost drain.
- ▶ 2½" (64 mm) diameter stem castors.
- ▶ Entire cabinet structure is foamed-in-place using high density, CFC free, polyurethane insulation.

ROUGH-IN DATA

Specifications subject to change without notice.
Chart dimensions rounded up to the nearest 1/8" (millimeters rounded up to next whole number).

Model	Lids	Capacity (Cu. Ft.) (liters)	Cabinet Dimensions (inches) (mm)			HP	Voltage	Amps	NEMA Config.	Cord Length (total ft.) (total m)	Crated Weight (lbs.) (kg)
			L	D	H*						
TFM-51FL	2	13.3 379	51 7/8 1318	26 1/8 664	31 5/8 804	1/3	115/60/1	4.1	5-15P	9 2.74	215 98

* Height does not include 3/4" (83 mm) for castors & 7/8" (23mm) for lid handle.



Printed in U.S.A.

APPROVALS:

AVAILABLE AT:

Model:
TFM-51FL

Horizontal Freezer: Glass Flat Lid



STANDARD FEATURES

DESIGN

- True's horizontal freezers are uniquely designed to promote high-profit frozen novelties in high impulse retail traffic areas. Ideal for bolstering incremental sales of frozen merchandise and seasonal specialties.

REFRIGERATION SYSTEM

- Factory engineered, self-contained, capillary tube system using environmentally friendly (CFC free) 134A refrigerant.
- Cold wall refrigeration system. Maintains -10° F (-23.33°C) cabinet temperature, ideal for both ice cream and frozen food.
- Condensing unit is accessed from behind grill on right side; slides out for easy maintenance.
- Manual defrost system; convenient drain located on front of cabinet.

CABINET CONSTRUCTION

- Exterior - non-peel or chip white laminated vinyl, durable and permanent; with gray mitered plastic top and lid frames.
- Interior - attractive, NSF approved, white aluminum liner; non-rust, peel or chip. 300 series stainless steel floor.
- Insulation - entire cabinet structure is foamed-in-place using high density, CFC free, polyurethane insulation.
- 2½" (64mm) diameter stem castors.

LIDS

- Tempered, hard coated, "Low-E", single pane glass slide lid assemblies. The latest in energy efficient technology; reduces solar heat gain and minimizes condensation.
- Designed for convenient access, fast service and attractive display.
- Lid lock standard.

MODEL FEATURES

- Self-contained, portable system. No plumbing required.

- Low profile design permits easier placement, saves aisle space.
- Interior mounted thermometer.
- NSF-7 compliant for open food product.

ELECTRICAL

- Unit completely pre-wired at factory and ready for final connection to a 115/60/1 phase, 15 amp dedicated outlet. Cord and plug set included.



115/60/1
NEMA-5-15R

OPTIONAL FEATURES/ACCESSORIES

Upcharge and lead times may apply.

- Black vinyl exterior.
- Heavy duty novelty baskets (accommodates 4).
- Dividers for novelty baskets.

PLAN VIEW

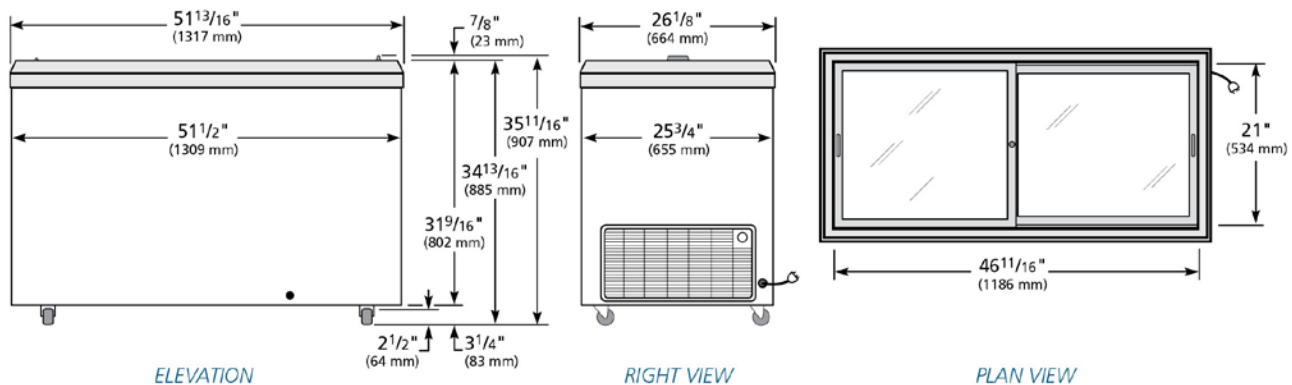

WARRANTY

One year warranty on all parts and labor and an additional 4 year warranty on compressor. (U.S.A. only)

METRIC DIMENSIONS ROUNDED UP TO THE NEAREST WHOLE MILLIMETER

SPECIFICATIONS SUBJECT TO CHANGE WITHOUT NOTICE



Model	Elevation	Right	Plan	3D	Back
TFM-51FL	TFEY89E	TFEY78S	TFEY89P	TFEY893	TFEY89B

TRUE FOOD SERVICE EQUIPMENT