

# Venus-6<sup>®</sup>



a COOL business



## Maintenance Free Condenser

The finless spiral condenser design prevents dust/dirt buildup allowing maximum long-term efficiency.



## LED Lighting

LED lighting lasts longer than fluorescent lighting, it reduces energy consumption and generates minimal heat. All of this makes LED lighting great for the environment.



## Electronic Temperature Control

The intelligent temperature control is programmed to ensure the correct operation of the equipment and maintain products at an optimum temperature.



## Steel Construction

Robust steel construction minimizes the use of plastic materials resulting in an environmental friendly design.



## Custom Graphics

Standard color: white. Optional: various cabinet colors or custom graphics.



## Hot Gas Evaporation

Hot gas heated drain pan for condensate evaporation that eliminates the need of floor drains or electric heaters.



## CABINET CONSTRUCTION

- High-density, CFC-Free, polyurethane insulation
- Large low-E double pane tempered curved glass front
- Exterior: Galvanized metal cabinet with powder coated painted surface (Standard)
- Interior: Easy to clean pre painted steel
- 4 Amp accessory receptacle
- Sliding Self Closing glass doors on back
- Door Lock

## REFRIGERATION

- Maintenance free condenser
- Automatic self defrost cycle doors on back

- Hot gas heated drain pan for condensate evaporation
- Electronic temp control
- Easy to reach components for repairs

## LIGHTING

- LED Perimeter lighting around glass

## SHELVING

- Adjustable Wire shelves

## OPERATING CONDITIONS

- The unit is best suited for an environment where temperatures remain below 75 F and humidity does not exceed 55%
- Areas with direct sunlight should also be avoided

## OPTIONS

- 6" Legs
- Castors
- Various cabinet colors (White Standard)
- Mirrored Interior
- Glass /Stainless Steel Shelves
- Stainless Exterior
- Cutting Board

## WARRANTY

- 1-year parts and labor
- 5 years compressor part

## NEMA

- Required NEMA configuration: 5-15R

Dimensions			Shelves	HP	Voltage	Amps	Weight
L	D	H					
72.8 in 1849 mm	35.5 in 902 mm	46.25 in 1175 mm	4	1/3+	120	11.5	542 lbs
				Net Capacity, cf: 30.3 (858 L)		Energy Consumption: 7.85 kw-hr /day	

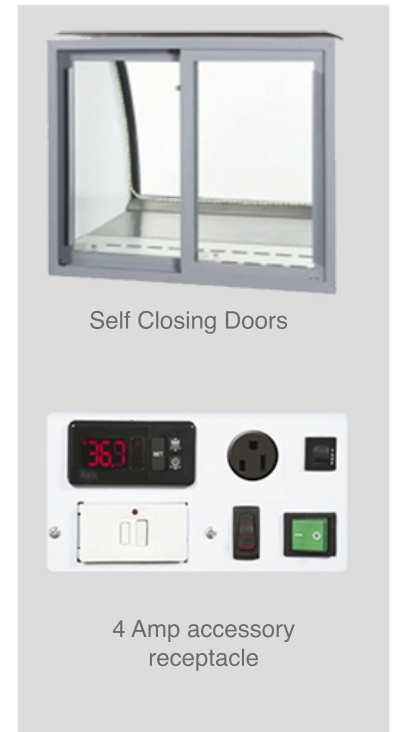

## Branding Dimensions

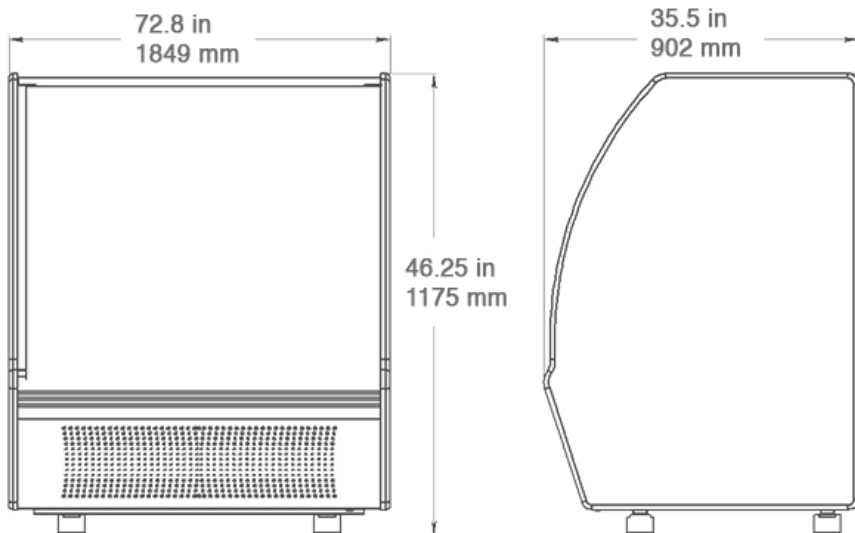

Consumption Equivalent to  
3.25 light bulbs of 100 watts

