



Maintenance Free Condenser

The finless spiral condenser design prevents dust/dirt buildup allowing maximum long-term efficiency.



Electronic Temperature Control

The intelligent temperature control is programmed to ensure the correct operation of the equipment and maintain products at an optimum temperature.



LED lighting

LED lighting lasts longer than fluorescent lighting, it reduces energy consumption and generates minimal heat. All of this makes LED lighting great for the environment.



Steel Construction

Robust steel construction minimizes the use of plastic materials resulting in an environmental friendly design.



Hot Gas Evaporation

Hot gas heated drain pan for condensate evaporation that eliminates the need of floor drains or electric heaters.



Custom Graphics

Standard color: white. Optional: various cabinet colors or custom graphics.

CABINET CONSTRUCTION

- High-density, CFC-Free, polyurethane insulation
- Large low-E double pane tempered curved glass front
- Exterior: Galvanized metal cabinet with powder coated painted surface (Standard)
- Interior: Easy to clean pre painted steel
- 4 Amp accessory receptacle
- Sliding Self Closing glass doors on back
- Door Lock

REFRIGERATION

- Maintenance free condenser
- Automatic self defrost cycle doors on back

- Hot gas heated drain pan for condensate evaporation
- Electronic temp control
- Easy to reach components for repairs

LIGHTING

- LED Perimeter lighting around glass

SHELVING

- Adjustable Wire shelves

OPERATING CONDITIONS

- The unit is best suited for an environment where temperatures remain below 75 F and humidity does not exceed 55%
- Areas with direct sunlight should also be avoided

OPTIONS

- 6" Legs
- Castors
- Various cabinet colors (White Standard)
- Mirrored Interior
- Glass /Stainless Steel Shelves
- Stainless Exterior
- Cutting Board

WARRANTY

- 1-year parts and labor
- 5 years compressor part

NEMA

- Required NEMA configuration: 5-15R

Dimensions			Shelves	HP	Voltage	Amps	Weight
L	D	H					
36.8 in 935 mm	35.5 in 902 mm	46.25 in 1175 mm	2	1/4	120	9.1	332 lbs
				Net Capacity, cf: 14.7 (416 L)		Energy Consumption: 5.55 kw-hr /day	

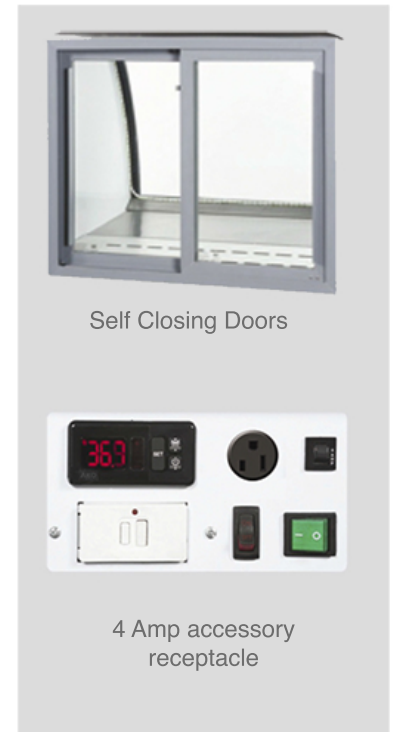

Branding Dimensions

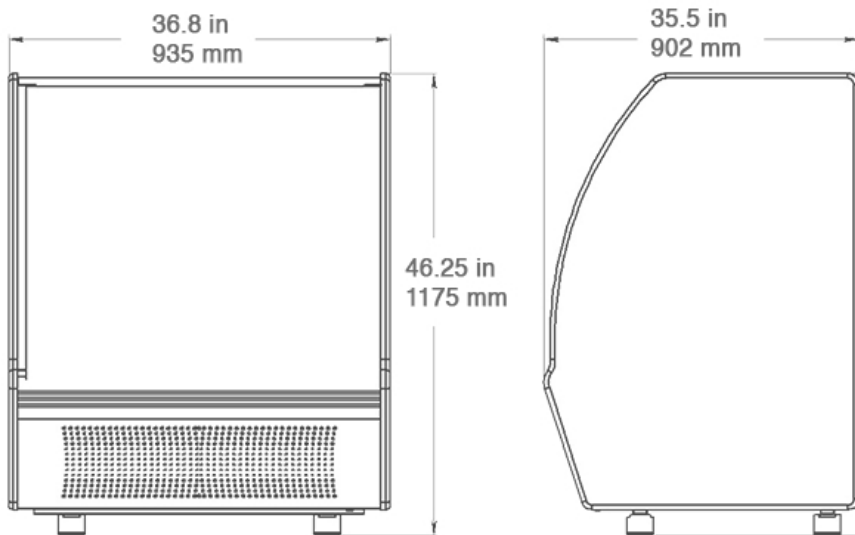

Consumption Equivalent to
2.31 light bulbs of 100 watts

